

# Model 6517A Electrometer

Service Manual

References to the Model 6517 also apply to the Model 6517A.

Contains Performance Verification, Calibration, and Repair Information

**KEITHLEY**

# WARRANTY

Keithley Instruments, Inc. warrants this product to be free from defects in material and workmanship for a period of 1 year from date of shipment.

Keithley Instruments, Inc. warrants the following items for 90 days from the date of shipment: probes, cables, rechargeable batteries, diskettes, and documentation.

During the warranty period, we will, at our option, either repair or replace any product that proves to be defective.

To exercise this warranty, write or call your local Keithley representative, or contact Keithley headquarters in Cleveland, Ohio. You will be given prompt assistance and return instructions. Send the product, transportation prepaid, to the indicated service facility. Repairs will be made and the product returned, transportation prepaid. Repaired or replaced products are warranted for the balance of the original warranty period, or at least 90 days.

## LIMITATION OF WARRANTY

This warranty does not apply to defects resulting from product modification without Keithley's express written consent, or misuse of any product or part. This warranty also does not apply to fuses, software, non-rechargeable batteries, damage from battery leakage, or problems arising from normal wear or failure to follow instructions.

THIS WARRANTY IS IN LIEU OF ALL OTHER WARRANTIES, EXPRESSED OR IMPLIED, INCLUDING ANY IMPLIED WARRANTY OF MERCHANTABILITY OR FITNESS FOR A PARTICULAR USE. THE REMEDIES PROVIDED HEREIN ARE BUYER'S SOLE AND EXCLUSIVE REMEDIES.

NEITHER KEITHLEY INSTRUMENTS, INC. NOR ANY OF ITS EMPLOYEES SHALL BE LIABLE FOR ANY DIRECT, INDIRECT, SPECIAL, INCIDENTAL OR CONSEQUENTIAL DAMAGES ARISING OUT OF THE USE OF ITS INSTRUMENTS AND SOFTWARE EVEN IF KEITHLEY INSTRUMENTS, INC., HAS BEEN ADVISED IN ADVANCE OF THE POSSIBILITY OF SUCH DAMAGES. SUCH EXCLUDED DAMAGES SHALL INCLUDE, BUT ARE NOT LIMITED TO: COSTS OF REMOVAL AND INSTALLATION, LOSSES SUSTAINED AS THE RESULT OF INJURY TO ANY PERSON, OR DAMAGE TO PROPERTY.



**Keithley Instruments, Inc.** • 28775 Aurora Road • Cleveland, OH 44139 • 440-248-0400 • Fax: 440-248-6168 • <http://www.keithley.com>

<b>BELGIUM:</b>	<b>Keithley Instruments B.V.</b>	Bergensesteenweg 709 • B-1600 Sint-Pieters-Leeuw • 02/363 00 40 • Fax: 02/363 00 64
<b>CHINA:</b>	<b>Keithley Instruments China</b>	Yuan Chen Xin Building, Room 705 • 12 Yumin Road, Dewai, Madian • Beijing 100029 • 8610-62022886 • Fax: 8610-62022892
<b>FRANCE:</b>	<b>Keithley Instruments Sarl</b>	B.P. 60 • 3, allée des Garays • 91122 Palaiseau Cédex • 01 64 53 20 20 • Fax: 01 60 11 77 26
<b>GERMANY:</b>	<b>Keithley Instruments GmbH</b>	Landsberger Strasse 65 • D-82110 Germering • 089/84 93 07-40 • Fax: 089/84 93 07-34
<b>GREAT BRITAIN:</b>	<b>Keithley Instruments Ltd</b>	The Minster • 58 Portman Road • Reading, Berkshire RG30 1EA • 0118-9 57 56 66 • Fax: 0118-9 59 64 69
<b>INDIA:</b>	<b>Keithley Instruments GmbH</b>	Flat 2B, WILOCRISSA • 14, Rest House Crescent • Bangalore 560 001 • 91-80-509-1320/21 • Fax: 91-80-509-1322
<b>ITALY:</b>	<b>Keithley Instruments s.r.l.</b>	Viale S. Gimignano, 38 • 20146 Milano • 02/48 30 30 08 • Fax: 02/48 30 22 74
<b>NETHERLANDS:</b>	<b>Keithley Instruments B.V.</b>	Postbus 559 • 4200 AN Gorinchem • 0183-635333 • Fax: 0183-630821
<b>SWITZERLAND:</b>	<b>Keithley Instruments SA</b>	Kriesbachstrasse 4 • 8600 Dübendorf • 01-821 94 44 • Fax: 01-820 30 81
<b>TAIWAN:</b>	<b>Keithley Instruments Taiwan</b>	1 Fl. 85 Po Ai Street • Hsinchu, Taiwan, R.O.C. • 886-3572-9077 • Fax: 886-3572-9031

# Model 6517A Electrometer Service Manual

©1998, Keithley Instruments, Inc.  
All rights reserved.  
Cleveland, Ohio, U.S.A.  
Second Printing, April 1999  
Document Number: 6517A-902-01 Rev. B

# Manual Print History

The print history shown below lists the printing dates of all Revisions and Addenda created for this manual. The Revision Level letter increases alphabetically as the manual undergoes subsequent updates. Addenda, which are released between Revisions, contain important change information that the user should incorporate immediately into the manual. Addenda are numbered sequentially. When a new Revision is created, all Addenda associated with the previous Revision of the manual are incorporated into the new Revision of the manual. Each new Revision includes a revised copy of this print history page.

Revision A (Document Number 6517A-902-01).....	September 1998
Revision B (Document Number 6517A-902-01).....	April 1999

# Safety Precautions

---

The following safety precautions should be observed before using this product and any associated instrumentation. Although some instruments and accessories would normally be used with non-hazardous voltages, there are situations where hazardous conditions may be present.

This product is intended for use by qualified personnel who recognize shock hazards and are familiar with the safety precautions required to avoid possible injury. Read the operating information carefully before using the product.

The types of product users are:

**Responsible body** is the individual or group responsible for the use and maintenance of equipment, for ensuring that the equipment is operated within its specifications and operating limits, and for ensuring that operators are adequately trained.

**Operators** use the product for its intended function. They must be trained in electrical safety procedures and proper use of the instrument. They must be protected from electric shock and contact with hazardous live circuits.

**Maintenance personnel** perform routine procedures on the product to keep it operating, for example, setting the line voltage or replacing consumable materials. Maintenance procedures are described in the manual. The procedures explicitly state if the operator may perform them. Otherwise, they should be performed only by service personnel.

**Service personnel** are trained to work on live circuits, and perform safe installations and repairs of products. Only properly trained service personnel may perform installation and service procedures.

Exercise extreme caution when a shock hazard is present. Lethal voltage may be present on cable connector jacks or test fixtures. The American National Standards Institute (ANSI) states that a shock hazard exists when voltage levels greater than 30V RMS, 42.4V peak, or 60VDC are present. **A good safety practice is to expect that hazardous voltage is present in any unknown circuit before measuring.**

Users of this product must be protected from electric shock at all times. The responsible body must ensure that users are prevented access and/or insulated from every connection point. In some cases, connections must be exposed to potential human contact. Product users in these circumstances must be trained to protect themselves from the risk of electric shock. If the circuit is capable of operating at or above 1000 volts, **no conductive part of the circuit may be exposed.**

As described in the International Electrotechnical Commission (IEC) Standard IEC 664, digital multimeter measuring circuits (e.g., Keithley Models 175A, 199, 2000, 2001, 2002, and 2010) are Installation Category II. All other instruments' signal terminals are Installation Category I and must not be connected to mains.

Do not connect switching cards directly to unlimited power circuits. They are intended to be used with impedance limited sources. NEVER connect switching cards directly to AC mains. When connecting sources to switching cards, install protective devices to limit fault current and voltage to the card.

Before operating an instrument, make sure the line cord is connected to a properly grounded power receptacle. Inspect the connecting cables, test leads, and jumpers for possible wear, cracks, or breaks before each use.

For maximum safety, do not touch the product, test cables, or any other instruments while power is applied to the circuit under test. ALWAYS remove power from the entire test system and discharge any capacitors before: connecting or disconnecting cables or jumpers, installing or removing switching cards, or making internal changes, such as installing or removing jumpers.

Do not touch any object that could provide a current path to the common side of the circuit under test or power line (earth) ground. Always make measurements with dry hands while standing on a dry, insulated surface capable of withstanding the voltage being measured.


The instrument and accessories must be used in accordance with its specifications and operating instructions or the safety of the equipment may be impaired.


Do not exceed the maximum signal levels of the instruments and accessories, as defined in the specifications and operating information, and as shown on the instrument or test fixture panels, or switching card.


When fuses are used in a product, replace with same type and rating for continued protection against fire hazard.

Chassis connections must only be used as shield connections for measuring circuits, NOT as safety earth ground connections.

If you are using a test fixture, keep the lid closed while power is applied to the device under test. Safe operation requires the use of a lid interlock.

If a  screw is present, connect it to safety earth ground using the wire recommended in the user documentation.

The  symbol on an instrument indicates that the user should refer to the operating instructions located in the manual.

The  symbol on an instrument shows that it can source or measure 1000 volts or more, including the combined effect of normal and common mode voltages. Use standard safety precautions to avoid personal contact with these voltages.

The **WARNING** heading in a manual explains dangers that might result in personal injury or death. Always read the associated information very carefully before performing the indicated procedure.

The **CAUTION** heading in a manual explains hazards that could damage the instrument. Such damage may invalidate the warranty.

Instrumentation and accessories shall not be connected to humans.

Before performing any maintenance, disconnect the line cord and all test cables.

To maintain protection from electric shock and fire, replacement components in mains circuits, including the power transformer, test leads, and input jacks, must be purchased from Keithley Instruments. Standard fuses, with applicable national safety approvals, may be used if the rating and type are the same. Other components that are not safety related may be purchased from other suppliers as long as they are equivalent to the original component. (Note that selected parts should be purchased only through Keithley Instruments to maintain accuracy and functionality of the product.) If you are unsure about the applicability of a replacement component, call a Keithley Instruments office for information.

To clean an instrument, use a damp cloth or mild, water based cleaner. Clean the exterior of the instrument only. Do not apply cleaner directly to the instrument or allow liquids to enter or spill on the instrument. Products that consist of a circuit board with no case or chassis (e.g., data acquisition board for installation into a computer) should never require cleaning if handled according to instructions. If the board becomes contaminated and operation is affected, the board should be returned to the factory for proper cleaning/servicing.

# Table of Contents

---

<b>1</b>	<b>Performance Verification</b>	
1.1	Introduction .....	1-1
1.2	Environmental conditions .....	1-1
1.3	Warm-up period .....	1-2
1.4	Line power .....	1-2
1.5	Recommended test equipment .....	1-2
1.5.1	Meter performance verification equipment .....	1-2
1.5.2	Voltage source verification equipment .....	1-3
1.5.3	Temperature verification equipment .....	1-3
1.5.4	Humidity verification equipment .....	1-4
1.6	Verification limits .....	1-4
1.7	Restoring default conditions .....	1-4
1.8	Offset voltage and bias current calibration .....	1-5
1.8.1	Front panel offset calibration .....	1-5
1.8.2	IEEE-488 bus offset calibration .....	1-5
1.9	Meter verification procedures .....	1-5
1.9.1	DC volts verification .....	1-6
1.9.2	DC amps verification .....	1-6
1.9.3	Coulombs verification .....	1-9
1.9.4	Ohms verification .....	1-11
1.10	Voltage source verification .....	1-14
1.11	Temperature verification .....	1-15
1.12	Humidity verification .....	1-16
<b>2</b>	<b>Calibration</b>	
2.1	Introduction .....	2-1
2.2	Environmental conditions .....	2-2
2.3	Warm-up period .....	2-2
2.4	Line power .....	2-2
2.5	Recommended calibration equipment .....	2-2
2.6	Calibration lock .....	2-4
2.6.1	Unlocking calibration .....	2-4
2.6.2	IEEE-488 bus calibration lock status .....	2-4
2.7	Calibration errors .....	2-4
2.7.1	Front panel error reporting .....	2-4
2.7.2	IEEE-488 bus error reporting .....	2-4
2.8	Front panel calibration .....	2-4
2.8.1	Front panel calibration summary .....	2-4
2.8.2	Front panel calibration procedure .....	2-6
2.9	IEEE-488 bus calibration .....	2-15

2.9.1	Calibration commands .....	2-15
2.9.2	IEEE-488 bus comprehensive calibration procedure .....	2-15
2.10	Single-point calibration .....	2-21
2.10.1	Front panel single-point calibration .....	2-21
2.10.2	IEEE-488 bus single-point calibration .....	2-22
2.11	Programming calibration dates .....	2-23

### 3 Calibration Command Reference

3.1	Introduction .....	3-1
3.2	Command summary .....	3-1
3.3	Miscellaneous commands .....	3-5
3.3.1	:INIT (:CALibration:PROTeCted:INITiate) .....	3-5
3.3.2	:LOCK (:CALibration:PROTeCted:LOCK) .....	3-5
3.3.3	:SWITCh? (:CALibration:PROTeCted:SWITCh?) .....	3-6
3.3.4	:SAVE (:CALibration:PROTeCted:SAVE) .....	3-6
3.3.5	:DATE (:CALibration:PROTeCted:DATE) .....	3-7
3.3.6	:NDUE (:CALibration:PROTeCted:NDUE) .....	3-7
3.3.7	:DATA? (:CALibration:PROTeCted:DATA?) .....	3-8
3.3.8	:OPT? (:CALibration:UNPRotected:OPTion?) .....	3-8
3.3.9	:CALTEMP (:CALibration:PROTeCted:CALTEMP) .....	3-8
3.4	Meter commands .....	3-9
3.4.1	Offset commands .....	3-9
3.4.2	Volts function calibration commands .....	3-10
3.4.3	Amps calibration commands .....	3-11
3.4.4	Coulombs calibration commands .....	3-13
3.5	Voltage source calibration commands .....	3-15
3.6	Temperature calibration commands .....	3-16
3.7	Humidity calibration commands .....	3-16
3.8	Calibration errors .....	3-17
3.8.1	Error query commands .....	3-17
3.8.2	Detecting calibration errors .....	3-18
3.9	Detecting calibration step completion .....	3-18
3.9.1	Using the *OPC? query .....	3-18
3.9.2	Using the *OPC command .....	3-18
3.9.3	Generating an SRQ on calibration complete .....	3-18

### 4 Routine Maintenance

4.1	Introduction .....	4-1
4.2	Line voltage selection .....	4-1
4.3	Line fuse replacement .....	4-1
4.4	INPUT connector cleaning .....	4-2
4.5	Firmware updates .....	4-2



<b>5</b>	<b>Troubleshooting</b>	
5.1	Introduction .....	5-1
5.2	Repair considerations .....	5-1
5.3	Power-on test .....	5-2
5.4	Front panel tests .....	5-2
5.4.1	KEYS test .....	5-2
5.4.2	DISPLAY PATTERNS test .....	5-2
5.4.3	Character set test .....	5-2
5.5	Principles of operation .....	5-2
5.5.1	Display board .....	5-4
5.5.2	Power supply .....	5-4
5.5.3	Digital board .....	5-6
5.5.4	Analog board .....	5-7
5.6	Circuit board checks .....	5-10
5.6.1	Display board checks .....	5-10
5.6.2	Power supply checks .....	5-11
5.6.3	Digital board checks .....	5-12
5.6.4	Analog board checks .....	5-13
<b>6</b>	<b>Disassembly</b>	
6.1	Introduction .....	6-1
6.2	Handling and cleaning precautions .....	6-1
6.2.1	PC board handling .....	6-1
6.2.2	Solder repairs .....	6-2
6.3	Special handling of static-sensitive devices .....	6-2
6.4	Case cover removal .....	6-2
6.5	PC board removal .....	6-2
6.5.1	Digital board removal .....	6-3
6.5.2	A/D converter board removal .....	6-3
6.5.3	Analog board removal .....	6-3
6.6	Front panel disassembly .....	6-4
6.7	Main CPU firmware replacement .....	6-4
6.8	Instrument re-assembly .....	6-5
6.9	Assembly drawings .....	6-5
<b>7</b>	<b>Replaceable Parts</b>	
7.1	Introduction .....	7-1
7.2	Parts lists .....	7-1
7.3	Ordering information .....	7-1
7.4	Factory service .....	7-1
7.5	Component layouts .....	7-1
<b>A</b>	<b>Specifications</b>	
<b>B</b>	<b>Calibration Messages</b>	
<b>C</b>	<b>Calibration Command Summary</b>	

# List of Illustrations

---

<b>1</b>	<b>Performance Verification</b>	
Figure 1-1	Connections for DC volts verification .....	1-7
Figure 1-2	Connections for 20pA–2μA range verification .....	1-7
Figure 1-3	Connections for 20μA–20mA range verification .....	1-9
Figure 1-4	Connections for coulombs verification .....	1-10
Figure 1-5	Connections for ohms verification (2MΩ–200MΩ ranges) .....	1-12
Figure 1-6	Connections for ohms verification (2GΩ–200GΩ ranges) .....	1-13
Figure 1-7	Connections for ohms verification (2TΩ–200TΩ ranges) .....	1-14
Figure 1-8	Shielded fixture construction .....	1-14
Figure 1-9	Connections for voltage source verification .....	1-15
Figure 1-10	Connections for temperature verification .....	1-16
Figure 1-11	Connections for humidity verification .....	1-17
<b>2</b>	<b>Calibration</b>	
Figure 2-1	Calibration unit connections .....	2-7
Figure 2-2	Connections for DC volts calibration .....	2-8
Figure 2-3	Connections for 20pA–2μA range calibration .....	2-9
Figure 2-4	Connections for 20μA–20mA range calibration .....	2-10
Figure 2-5	Connections for coulombs calibration .....	2-11
Figure 2-6	Connections for temperature calibration .....	2-12
Figure 2-7	Connections for voltage source calibration .....	2-13
Figure 2-8	Connections for humidity calibration .....	2-14
<b>4</b>	<b>Routine Maintenance</b>	
Figure 4-1	Rear panel .....	4-2
<b>5</b>	<b>Troubleshooting</b>	
Figure 5-1	Model 6517A overall block diagram .....	5-3
Figure 5-2	Display board block diagram .....	5-4
Figure 5-3	Power supply block diagram .....	5-5
Figure 5-4	Digital board block diagram .....	5-7
Figure 5-5	Analog board block diagram .....	5-8
Figure 5-6	Preamp configurations .....	5-9

## **B Calibration Messages**

Figure B-1	EERR? query response (calibration execution errors) .....	B-6
Figure B-2	VERR? query response (voltage function cal errors) .....	B-6
Figure B-3	IERR? query response (current function cal errors) .....	B-6
Figure B-4	CERR? query response (coulombs function cal errors) .....	B-7
Figure B-5	TERR? query response (temperature function cal errors) .....	B-7
Figure B-6	HERR? query response (humidity function cal errors) .....	B-7
Figure B-7	SERR? query response (voltage source cal errors) .....	B-7
Figure B-8	FERR? query response (factor cal errors) .....	B-7

# List of Tables

---

<b>1</b>	<b>Performance Verification</b>	
Table 1-1	Recommended test equipment for meter performance verification .....	1-3
Table 1-2	Recommended test equipment for voltage source verification .....	1-3
Table 1-3	Temperature verification equipment .....	1-3
Table 1-4	Humidity verification equipment .....	1-4
Table 1-5	Limits for DC volts verification .....	1-6
Table 1-6	Reading limits for verification of 20pA-2 $\mu$ A ranges .....	1-8
Table 1-7	Limits for 20 $\mu$ A–20mA range verification .....	1-9
Table 1-8	Limits for coulombs verification .....	1-10
Table 1-9	Limits for ohms verification .....	1-12
Table 1-10	Limits for voltage source verification .....	1-15
Table 1-11	Reading limits for temperature verification .....	1-15
Table 1-12	Limits for humidity verification .....	1-16
<b>2</b>	<b>Calibration</b>	
Table 2-1	Recommended calibration equipment .....	2-3
Table 2-2	Front panel calibration summary .....	2-5
Table 2-3	Volts calibration summary .....	2-8
Table 2-4	Amps calibration summary (20pA–2 $\mu$ A ranges) .....	2-10
Table 2-5	Amps calibration summary (20 $\mu$ A-20mA ranges) .....	2-10
Table 2-6	Coulombs calibration summary .....	2-12
Table 2-7	Voltage source calibration summary .....	2-13
Table 2-8	Humidity calibration summary .....	2-14
Table 2-9	Offset calibration steps .....	2-15
Table 2-10	IEEE-488 bus volts function calibration summary .....	2-16
Table 2-11	IEEE-488 bus amps calibration summary (20pA-2 $\mu$ A ranges) .....	2-18
Table 2-12	IEEE-488 bus amps calibration summary (20 $\mu$ A-20mA ranges) .....	2-18
Table 2-13	IEEE-488 bus coulombs calibration summary .....	2-19
Table 2-14	IEEE-488 bus voltage source calibration summary .....	2-20
Table 2-15	IEEE-488 bus humidity calibration summary .....	2-21

<b>3</b>	<b>Calibration Command Reference</b>	
Table 3-1	IEEE-488 bus calibration command summary .....	3-2
Table 3-2	Volts function calibration commands and parameters .....	3-10
Table 3-3	Amps function calibration commands and parameters (all ranges, without calibration standard) .....	3-11
Table 3-4	Amps function calibration commands and parameters (20pA-2 $\mu$ A ranges, using calibration standard) .....	3-12
Table 3-5	Coulombs function calibration commands and parameters (without calibration standard) .....	3-13
Table 3-6	Coulombs function calibration commands and parameters (using calibration standard) .....	3-14
Table 3-7	Voltage source calibration commands .....	3-15
<b>4</b>	<b>Routine Maintenance</b>	
Table 4-1	Power line fuse .....	4-2
<b>5</b>	<b>Troubleshooting</b>	
Table 5-1	Power supply circuits .....	5-6
Table 5-2	Display board checks .....	5-10
Table 5-3	Power supply checks .....	5-11
Table 5-4	Digital board checks .....	5-12
Table 5-5	Analog board checks .....	5-13
<b>7</b>	<b>Replaceable Parts</b>	
Table 7-1	Model 6517A ADC board, parts list .....	7-2
Table 7-2	Model 6517A display board, parts list .....	7-5
Table 7-3	Model 6517A analog board, parts list .....	7-6
Table 7-4	Model 6517A digital board, parts list .....	7-10
Table 7-5	Model 6517A mechanical board, parts list .....	7-12
Table 7-6	Model 6517A miscellaneous parts list .....	7-13
<b>B</b>	<b>Calibration Messages</b>	
Table B-1	Calibration error responses .....	B-2
Table B-2	Calibration error query commands .....	B-4
Table B-3	Calibration constants returned by :CAL:PROT:DATA? query .....	B-5
<b>C</b>	<b>Calibration Command Summary</b>	
Table C-1	Calibration commands .....	C-1

# Performance Verification

---

## 1.1 Introduction

The procedures in this section are intended to verify that Model 6517A accuracy is within the limits stated in the instrument one-year accuracy specifications. These procedures can be performed when the instrument is first received to ensure that no damage has occurred during shipment. Verification may also be performed whenever there is a question of instrument accuracy, or following calibration, if desired.

### WARNING

**The information in this section is intended for use only by qualified service personnel. Do not attempt these procedures unless you are qualified to do so.**

### NOTE

If the instrument is still under warranty, and its performance is outside specified limits, contact your Keithley representative or the factory to determine the correct course of action.

This section includes the following:

- 1.2 Environmental conditions:** Covers the temperature and humidity limits for verification.
- 1.3 Warm-up period:** Describes the length of time the Model 6517A should be allowed to warm up before testing.

- 1.4 Line power:** Covers power line voltage ranges during testing.
- 1.5 Recommended equipment:** Summarizes recommended test equipment and pertinent specifications.
- 1.6 Verification limits:** Explains how reading limits were calculated.
- 1.7 Restoring default conditions:** Gives step-by-step procedures for restoring default conditions before each test procedure.
- 1.8 Offset voltage and bias current calibration:** Covers methods to null offset voltage and bias current.
- 1.9 Meter verification procedures:** Details procedures to verify accuracy of Model 6517A measurement functions: volts, amps, coulombs, and ohms.
- 1.10 Voltage source verification:** Covers verifying voltage source output accuracy.
- 1.11 Temperature verification:** Explains how to check temperature measurement accuracy.
- 1.12 Humidity verification:** Summarizes the basic procedure to check humidity measurement accuracy.

## 1.2 Environmental conditions

Verification measurements should be made at an ambient temperature of 18° to 28°C (65° to 82°F), and at a relative humidity of less than 70% unless otherwise noted.

### 1.3 Warm-up period

The Model 6517A must be allowed to warm up for at least one hour before performing the verification procedures. If the instrument has been subjected to temperature extremes (outside the range stated in paragraph 1.2), allow additional time for internal temperatures to stabilize. Typically, it takes one additional hour to stabilize a unit that has been in an environment 10°C (18°F) above or below the specified temperature range.

The test equipment should also be allowed to warm up for the minimum period specified by the manufacturer.

### 1.4 Line power

The Model 6517A should be tested while operating from a line voltage within the range determined by the rear panel LINE VOLTAGE switch setting, at a frequency of 50 or 60Hz.

### 1.5 Recommended test equipment

The following paragraphs list test equipment recommended for performing the verification procedures for the various Model 6517A functions. Alternate equipment may be used as long as that equipment has specifications comparable to or better than those listed in the table.

#### NOTE

Make all input low connections directly to the triax INPUT connector instead of using COMMON to avoid internal voltage drops that could affect measurement accuracy. Use the connecting methods shown in this section to avoid this problem.

### 1.5.1 Meter performance verification equipment

Table 1-1 lists all test equipment required for verifying the measurement accuracy of Model 6517A meter functions. This equipment will allow you to check the accuracy of the instrument volts, amps, and coulombs functions.

#### NOTE

The Model 5156 Electrometer Calibration Standard is recommended for verifying accuracy of the 20pA-2μA amps ranges, the 2GΩ-200GΩ resistance ranges, and all coulombs ranges. Alternate resistance and capacitance standards may be substituted as long as those standards are characterized to an uncertainty at least four times better than equivalent Model 6517A specifications.

#### NOTE

The ohms function and its accuracy are derived from the voltage source and current measurement function and their respective specifications. If both the voltage source and current measurement function meet their accuracy specifications, it is not necessary to independently verify ohms function accuracy. The ohms verification procedure in this manual (paragraph 1.9.4) is provided for those who require Artifact Standard Verification. Because of limitations in high-value standard resistor accuracy, characterized resistors are required in addition to the Model 5156 Electrometer Calibration Standard.

**Table 1-1**

Recommended test equipment for meter performance verification

Mfg.	Model	Description	Specifications
Fluke	5700A	Calibrator	$\pm 5$ ppm basic uncertainty. <sup>1</sup> DC Voltage: 1.9V: $\pm 7$ ppm 19V: $\pm 5$ ppm 190V: $\pm 7$ ppm DC current: 19 $\mu$ A: $\pm 576$ ppm 190 $\mu$ A: $\pm 103$ ppm 1.9mA: $\pm 55$ ppm 19mA: $\pm 55$ ppm Ohms: 1.9M $\Omega$ (nominal) 19M $\Omega$ (nominal) 100M $\Omega$ (nominal)
Keithley	5156	Electrometer Calibration Standard	100M $\Omega^2$ [2 $\mu$ A, 200nA] 1G $\Omega$ [2nA, 20nA, 2G $\Omega$ ] 10G $\Omega$ [200pA, 20G $\Omega$ ] 100G $\Omega$ [20pA, 200G $\Omega$ ] 1nF [2nC, 20nC] 100nF [200nC, 2 $\mu$ C] 1T $\Omega^3$ 10T $\Omega$ 100T $\Omega$
Keithley	4801	Low-noise coax cable	
Keithley	7078-TRX-BNC	Triax-to BNC adapter BNC to dual banana plug adapter	
Keithley	237-ALG-2	Triax to alligator clip cable*	
Keithley	CAP-31	Triax shielding cap	

1. 90-day calibrator specifications shown include total absolute uncertainty at specified output.

2. Equivalent resistance and capacitance standards may be substituted if characterized to four times better uncertainty than equivalent Model 6517A specifications.

3. Resistors must be characterized to four times better uncertainty than equivalent Model 6517A specifications.

\*Short red and black clips to make triax short.

## 1.5.2 Voltage source verification equipment

Table 1-2 summarizes equipment recommended to perform voltage source verification.

**Table 1-2**

Recommended test equipment for voltage source verification

Mfg.	Model	Description	Specifications*
Keithley	2001	Multimeter	200V range: $\pm 41$ ppm 1000V range: $\pm 47$ ppm
Keithley	8607	Dual banana plug cable	

\*1-year multimeter specifications are for full-range input.

## 1.5.3 Temperature verification equipment

Table 1-3 lists temperature verification equipment.

**Table 1-3**

Temperature verification equipment

Mfg.	Model	Description	Specifications
Omega	CL-307K	Type K Thermo-couple Calibrator/Simulator	-190°C to +1300°C, $\pm 0.4\%$



### 1.5.4 Humidity verification equipment

Table 1-4 summarizes test equipment recommended to verify the accuracy of the Model 6517A humidity measurement function.

**Table 1-4**  
Humidity verification equipment

Mfg.	Model	Description	Specifications*
Fluke	5700A	DC voltage calibrator  Banana plugs to clip leads  2, 1 in. lengths of solid #20AWG wire	0V, 0.5V, 1V, ±5ppm basic accuracy

\* DC voltage calibrator with better than 0.25% basic accuracy may be substituted.

### 1.6 Verification limits

The verification limits stated in this section have been calculated using only Model 6517A one-year accuracy specifications, and do not include test equipment uncertainty. In cases where the Model 6517A apparently does not meet its published specifications based on stated reading limits, reading limits should be recalculated using both Model 6517A accuracy specifications and the total absolute uncertainty of the verification equipment.

#### Reading limit calculation example

As an example of how reading limits can be calculated using test equipment uncertainty, assume that the 200µA range is being tested using a 190µA input value, and the various specifications are as follows:

- Model 6517A 200µA range one-year accuracy: ±(0.1% of reading + 5 counts)
- Calibrator total absolute uncertainty at 190µA output: ±103ppm

The calculated limits are:

Reading limits =  $190\mu\text{A} \pm [(190\mu\text{A} \times 0.1\% + 0.005\mu\text{A}) + (190\mu\text{A} \times 103\text{ppm})]$

Reading limits =  $190\mu\text{A} \pm 0.21457\mu\text{A}$

Reading limits = 189.7854µA to 190.2146µA

### 1.7 Restoring default conditions

Before performing **each** performance verification procedure, restore instrument bench default conditions as follows:

1. From the normal display mode, press the MENU key. The instrument will display the following:  
MAIN MENU  
SAVESETUP COMMUNICATION CAL
2. Select SAVESETUP, and press ENTER. The following will be displayed:  
SETUP MENU  
SAVE RESTORE POWERON RESET
3. Select RESET, and press ENTER. The display will then appear as follows:  
RESET ORIGINAL DFLTS  
BENCH GPIB
4. Select BENCH, then press ENTER. The following will be displayed:  
RESETTING INSTRUMENT  
ENTER to confirm; EXIT to abort
5. Press ENTER again to confirm instrument reset. The instrument will return to normal display with bench defaults restored.

## 1.8 Offset voltage and bias current calibration

Before performing meter verification procedures (checking accuracy of the volts, amps, coulombs, and ohms measurement functions), the offset voltage and bias current calibration procedure should be performed, as described in the following paragraphs.

### 1.8.1 Front panel offset calibration

To calibrate voltage offset and input bias current from the front panel, proceed as follows:

1. Turn on the Model 6517A, and allow a one-hour warm-up period before calibrating offsets.
2. From normal display, press the MENU key.
3. Select CAL, then press ENTER.
4. Choose OFFSET-ADJ, then press ENTER. The instrument will prompt you as follows:  
CONNECT TRIAX SHORT  
Press ENTER to continue.
5. Connect the shorted triax cable (short red and black clips) to the rear panel INPUT connector, then press ENTER. The instrument will then perform voltage offset calibration, during which it will display the following message:  
Performing V offset calibration
6. The Model 6517A will then prompt you as follows:  
CONNECT TRIAX CAP  
Press ENTER to continue
7. Removing the triax short, and connect the triax shielding (non-shorting) cap in its place.
8. Press ENTER. The Model 6517A will perform offset current verification, during which it will display the following message:  
Performing I offset calibration
9. Press EXIT as necessary to return to normal display once both offset calibration procedures are completed.

### 1.8.2 IEEE-488 bus offset calibration

To calibrate voltage offset and input bias current using IEEE-488 bus commands, proceed as follows:

1. Turn on the Model 6517A, and allow a one-hour warm-up period before calibrating voltage and current offsets.
2. Connect the triax shorting cable to the rear panel INPUT connector, then send the following command over the IEEE-488 bus:  
:CAL:UNPR:VOFF

Wait until the instrument completes this step before continuing.

3. Removing the triax shorting cable, and connect the triax shielding (non-shorting) cap in its place.
4. Send the following command to the instrument over the IEEE-488 bus:  
:CAL:UNPR:IOFF
5. Wait until the instrument completes bias current calibration, then remove the cap from the rear panel INPUT connector.

## 1.9 Meter verification procedures

The following paragraphs contain procedures for verifying instrument one-year accuracy specifications for the following functions:

- DC volts
- DC amps
- Coulombs
- Ohms

### NOTE

Ohms accuracy specifications are derived from both amps and voltage source specifications. Thus, it is not necessary to separately verify the accuracy of the ohms function. As long as the amps function and voltage source meet their respective accuracy specifications, ohms function accuracy is assured.

If the Model 6517A meter functions are out of specifications and not under warranty, refer to the calibration procedures in Section 2.

### WARNING

**The maximum INPUT level (HI to LO) is 250V peak. The maximum common-mode voltage is 500V peak.**

**Exceeding these values may cause damage to the unit.**

**Some of the procedures in this section may expose you to hazardous voltages. Use standard safety precautions when such hazardous voltages are encountered to avoid personal injury caused by electric shock.**

**NOTE**

Do not connect test equipment to the Model 6517A through a scanner or other switching equipment.

**1.9.1 DC volts verification**

DC voltage accuracy is verified by applying accurate DC voltages from a DC voltage calibrator to the Model 6517A INPUT jack and verifying that the displayed readings fall within specified ranges.

Follow the steps below to verify DCV measurement accuracy.

1. Connect the Model 6517A to the calibrator, as shown in Figure 1-1. Be sure to connect calibrator HI to Model 6517A INPUT HI and calibrator LO to the Model 6517A INPUT LO using the low-noise coax cable, BNC-to-dual banana plug adapter, and the triax-to-BNC adapter as shown.
2. Turn on the Model 6517A and the calibrator, and allow a one-hour warm-up period before making measurements.
3. Restore Model 6517A factory default conditions, as explained in paragraph 1.7.
4. Select the Model 6517A 2V DC range, and make sure the filter is enabled.

**NOTE**

Do not use auto-ranging for any of the verification tests because auto-range hysteresis may cause the Model 6517A to be on an incorrect range.

5. With zero check enabled, press REL to zero correct the instrument.
6. Set the calibrator output to 0.00000VDC, and disable zero check. Allow the reading to settle completely before continuing.
7. Enable the Model 6517A REL mode. Leave REL enabled for the remainder of the DC volts verification tests.
8. Set the calibrator output to +1.90000VDC, and allow the reading to settle.
9. Verify that the Model 6517A reading is within the limits summarized in Table 1-5.
10. Repeat steps 8 and 9 for the 20V and 200V ranges using the test voltages listed in Table 1-5.
11. Repeat the procedure for each of the ranges with negative voltages of the same magnitude as those listed in Table 1-5.

**Table 1-5**

*Limits for DC volts verification*

<b>6517A DCV range</b>	<b>Applied DC voltage</b>	<b>Reading limits (18° to 28°C, 1 year)</b>
2V	1.90000V	1.89949V to 1.900515V
20V	19.0000V	18.9950V to 19.0050V
200V	190.000V	189.883V to 190.117V

1. Repeat procedure for negative voltages of same magnitude.
2. Reading limits shown are calculated only from Model 6517A one-year accuracy specifications and do not include test equipment uncertainty.

**1.9.2 DC amps verification**

DC amps accuracy is checked by applying accurate DC currents to the instrument INPUT jack and then verifying that the current readings fall within appropriate limits. Note that two separate current verification procedures are provided because of the different equipment required. Basically, the amps verification procedures are divided into the following two groups:

- 20pA – 2μA range verification using a DC voltage calibrator and the Keithley Model 5156 Electrometer Calibration Standard, which contains standard resistors.
- 20μA – 20mA range verification using a DC current calibrator.

**20pA–2μA range verification**

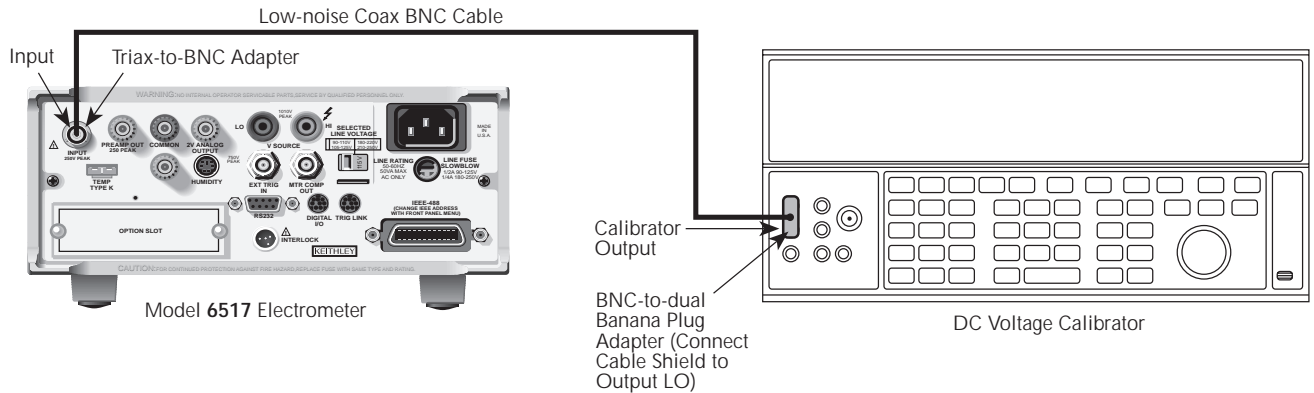
Accuracy of the 20pA–2μA ranges is verified by applying accurate currents derived from DC voltages and resistance standards, and then checking the displayed readings against calculated limits. Note that it is necessary to calculate reading limits for each range separately from the exact values of the resistance standards supplied with those standards.

Follow the steps below to verify measurement accuracy of the 20pA to 2μA ranges.

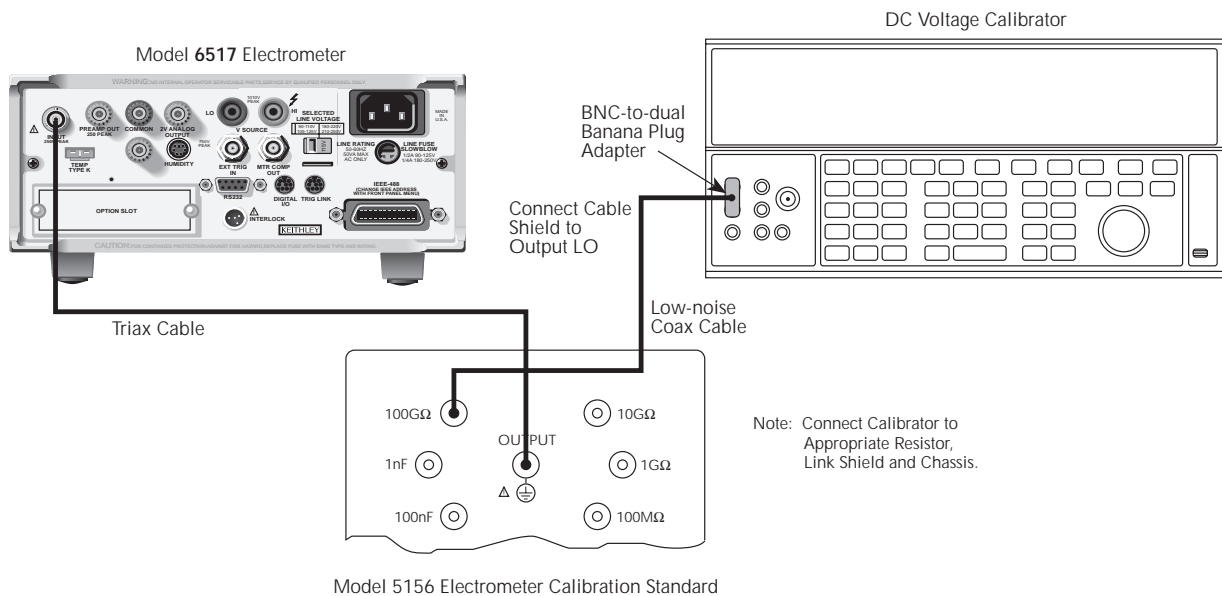
1. Connect the Model 6517A to the DC voltage calibrator and the calibration standards box, as shown in Figure 1-2. Initially, make connections to the calibration standard using the 100GΩ resistor.

**NOTE**

It is not necessary to connect the calibration standard to the Model 6517A DIGITAL I/O port when performing the verification procedures.



**Figure 1-1**  
Connections for DC volts verification



**Figure 1-2**  
Connections for 20pA–2µA range verification

2. Turn on the Model 6517A and the DC calibrator, and allow a one-hour warm-up period before making measurements.
3. Restore Model 6517A factory default conditions, as explained in paragraph 1.7.
4. Select the amps function and the 20pA range on the Model 6517A.
5. With zero check enabled, press REL to zero correct the instrument.
6. Set the calibrator output to 0.0000V, then disable zero check. Enable the REL mode to null offsets.
7. Record the actual resistance values (see Model 5156 calibration data) in the appropriate column of Table 1-6.
8. Calculate the actual calibration voltage from the desired current and the actual value of the 100GΩ resistor as determined from the calibration data as follows:

$$V = IR$$

Where: I = desired current applied to Model 6517A  
 V = actual voltage from DC voltage calibrator  
 R = actual value of calibration standard resistance

After calculating the actual voltage values, record them where indicated in Table 1-6.

9. Set the DC calibrator to the actual voltage.
10. Make sure the DC voltage calibrator is in operate.
11. Allow the reading to settle completely, then note the reading on the Model 6517A display. Verify that the reading is within the limits listed in Table 1-6.
12. Reverse the calibrator voltage polarity, then make sure the magnitude of current reading is within limits.
13. Repeat steps 4 through 12 for the 200pA through 2μA ranges using the appropriate DC voltage and standard resistor listed in Table 1-6. For each range, be sure to:
  - Compute the actual calibrator voltage.
  - Set the DC voltage calibrator to the correct setting.
  - Null offsets using REL.
  - Make connections to the appropriate standard resistance in the calibration standard test box.

**20μA – 20mA range verification**

Measurement accuracy of the 20μA-20mA ranges is verified by applying accurate currents from a DC current calibrator and then verifying that the Model 6517A reading is within specified limits.

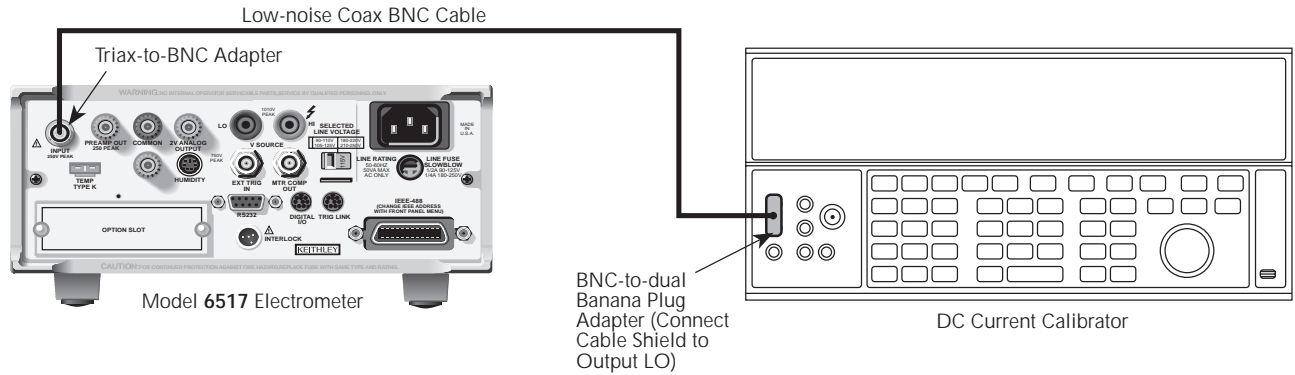
Proceed as follows:

1. Connect the Model 6517A to the DC current calibrator using the low-noise coax cable, triax-to-BNC adapter, and BNC-to-dual banana plug adapter, as shown in Figure 1-3. Be sure to connect the calibrator output HI terminal to Model 6517A INPUT HI, and connect calibrator output LO to Model 6517A INPUT LO.
2. Turn on the Model 6517A and the calibrator, and allow a one-hour warm-up period before making measurements.
3. Restore Model 6517A factory default conditions, as explained in paragraph 1.7.
4. Select the amps function and the 20μA range on the Model 6517A.
5. With zero check enabled, press REL to zero correct the instrument.
6. Set the calibrator output to 0.000μA then disable zero check. Enable REL to null offsets.
7. Set the calibrator output to +19.0000μADC, and disable Model 6517A zero check.
8. Allow the reading to settle, then verify that the Model 6517A reading is within the limits for the selected measurement range, as summarized in Table 1-7.
9. Repeat steps 5 through 8 for the remaining ranges and currents listed in Table 1-7.
10. Repeat the procedure for each of the ranges with negative currents of the same magnitude as those listed in Table 1-7.

**Table 1-6**  
Reading limits for verification of 20pA-2μA ranges

6517A range	Nominal voltage value	Standard resistor value	Actual resistance	Applied current	Actual voltage*	Reading limits (1 year, 18° to 28°C)
20pA	1.9000V	100GΩ	_____Ω	19pA	_____V	18.8070 to 19.1930pA
200pA	1.9000V	10GΩ	_____Ω	190pA	_____V	188.095 to 191.905pA
2nA	1.9000V	1GΩ	_____Ω	1.9nA	_____V	1.89590 to 1.91410nA
20nA	1.9000V	100MΩ	_____Ω	19nA	_____V	18.9615 to 19.0385nA
200nA	19.0000V	100MΩ	_____Ω	190nA	_____V	189.615 to 190.385nA
2μA	190.000V	100MΩ	_____Ω	1.9μA	_____V	1.89800 to 1.90200μA

\* Voltage calculated as follows:  $V = IR$ , where V is calibrator voltage, R is actual value of resistance standard, and I is desired applied current.



**Figure 1-3**  
Connections for 20µA–20mA range verification

**Table 1-7**  
Limits for 20µA–20mA range verification

6517A range	Applied DC current	Reading limits (1 year, 18° to 28°C)
20µA	19.0000µA	18.9805µA to 19.0195µA
200µA	190.000µA	189.805µA to 190.195µA
2mA	1.90000mA	1.89800mA to 1.90200mA
20mA	19.0000mA	18.9805mA to 19.0195mA

1. Repeat procedure for negative currents.
2. Reading limits shown calculated only from Model 6517A one-year accuracy specifications and do not include test equipment uncertainty.

### 1.9.3 Coulombs verification

Coulombs verification is performed by applying accurately known charge values derived from a voltage source and a capacitor to the Model 6517A INPUT jack, and then verifying that Model 6517A readings fall within specified limits.

Follow the steps below to verify coulombs measurement accuracy.

1. Connect the Model 6517A to the calibration standard then to the voltage calibrator, as shown in Figure 1-4. Initially, make the connections to the InF capacitor.
2. Turn on the Model 6517A and the DC voltage calibrator, and allow a one-hour warm-up period before making measurements.
3. Restore Model 6517A factory default conditions, as explained in paragraph 1.7. Also make sure that the offset-nulling procedure discussed in paragraph 1.8 has been performed.

4. Select the coulombs function and the 2nC range on the Model 6517A.
5. Compute the desired calibrator voltages as follows:

$$V = \frac{Q}{C}$$

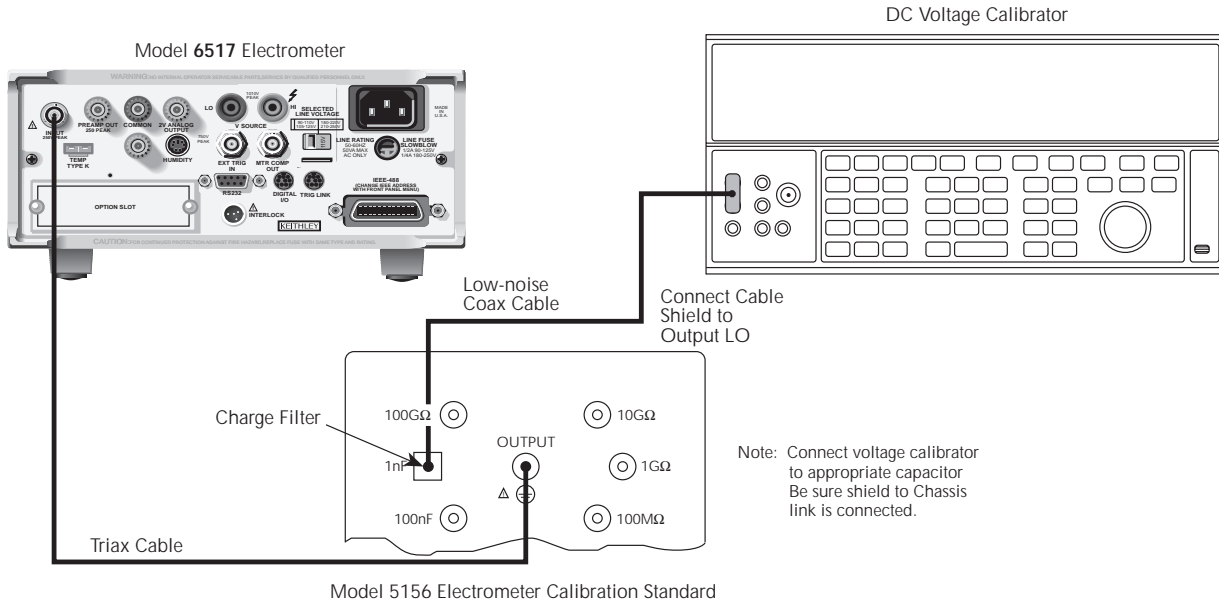
Where: V = calibrator voltage in volts

Q = charge in coulombs

C = standard capacitance value in farads

After calculating the voltage values, enter them where indicated in Table 1-8.

6. With zero check enabled, press REL to zero correct the instrument.
7. Disable zero check, and set the voltage calibrator output to 0.0000V.
8. Set the calibrator output to the calculated voltage. Allow the reading to settle completely.
9. Compare the Model 6517A displayed reading with the limits shown in Table 1-8.
10. Set the calibrator output to 0.000000V, and enable zero check.
11. Repeat steps 5 through 10 for the remaining ranges listed in Table 1-8. For each range, be sure to:
  - Set the Model 6517A to the appropriate range.
  - Make connections to the correct capacitor in the calibration standard.
  - Set the calibrator to 0V with zero check disabled.
  - Set the voltage calibrator to the calculated voltage value.
  - Compare the Model 6517A reading with the stated reading limits.



**Figure 1-4**  
Connections for coulombs verification

**Table 1-8**  
Limits for coulombs verification

6517A range	Standard capacitor <sup>1</sup>	Nominal voltage value <sup>2</sup>	Charge	Actual voltage <sup>3</sup>	Reading limits (1 year, 18° to 28°C)
2nC	1nF	1.90000V	1.9nC	_____ V	1.89235 to 1.90765nC
20nC	1nF	19.0000V	19nC	_____ V	18.9235 to 19.0765nC
200nC	1nF	190.000V	190nC	_____ V	189.235 to 190.765nC
2μC	100nF	19.0000V	1.9μC	_____ V	1.89235 to 1.90765μC

<sup>1</sup>Nominal value of capacitor in calibration unit.  
<sup>2</sup>DC voltage applied by calibrator (nominal value)  
<sup>3</sup>Actual voltage:  $V=Q/C$ .

### 1.9.4 Ohms verification

Ohms function accuracy is verified by connecting accurate resistance standards to the Model 6517A and then verifying that the readings on the display fall within the required ranges. The following paragraphs discuss the required resistance standards, how to compute voltage source values, and provide detailed procedures for verifying accuracy of the ohms function.

#### NOTE

Ohms specifications are derived from amps and voltage source specifications. Thus, it is not necessary to verify ohms separately. However, the following procedure is provided for those who wish to perform an Artifact Standard Verification.

#### Required standard resistors

Resistance standards required include:

- Resistance calibrator (2M $\Omega$ -200M $\Omega$  ranges)
- Model 5156 Electrometer Calibration Standard (2G $\Omega$ -200G $\Omega$  ranges)
- Characterized resistors (2T $\Omega$ -200T $\Omega$  ranges)

See Table 1-1 for detailed information on these recommended standard resistors.

#### Calculating ohms reading limits

Ohms reading limits must be calculated from the actual standard resistance value and the appropriate Model 6517A specifications. For example, assume that the 2G $\Omega$  range is being tested, and the specifications are:

- Model 6517A 2G $\Omega$  range accuracy:  $\pm(0.225\%$  of rdg + 1 count)
- 1G $\Omega$  resistor actual value: 1.025G $\Omega$

Calculated reading limits are as follows:

$$\text{Reading limits} = 1.025\text{G}\Omega \pm [(1.025\text{G}\Omega \times 0.225\%) + 10\text{k}\Omega]$$

$$\text{Reading limits} = 1.025\text{G}\Omega \pm 2.31625\text{M}\Omega$$

$$\text{Reading limits} = 1.02268\text{G}\Omega \text{ to } 1.02732\text{G}\Omega$$

#### NOTE

Before performing the ohms verification procedures, calculate the reading limits for each range, and enter the limits where indicated in Table 1-9.

#### Instrument setup

Before performing the ohms verification procedures, you must make certain that the instrument is properly configured as follows. Failure to do so will result in erroneous or erratic measurements.

#### Step 1: Select the auto voltage source mode

1. Press CONFIG and then R.
2. Select VSOURCE in the displayed menu, and then press ENTER.
3. Select AUTO in the VSOURCE SETTING menu, and then press ENTER.
4. Press EXIT to return to normal display.

#### Step 2: Select internal voltage source connections

1. Press CONFIG and then OPER.
2. Select METER-CONNECT in the CONFIGURE V-SOURCE menu, and then press ENTER.
3. Select ON in the SOURCE-METER CONNECT menu, and then press ENTER.
4. Press EXIT to return to normal display.

#### Step 3: Disable voltage source resistive limit

1. Press CONFIG and then OPER.
2. Select RESISTIVE-LIMIT in the displayed menu, and then press ENTER.
3. Select OFF, and then press ENTER.
4. Press EXIT to return to normal display.

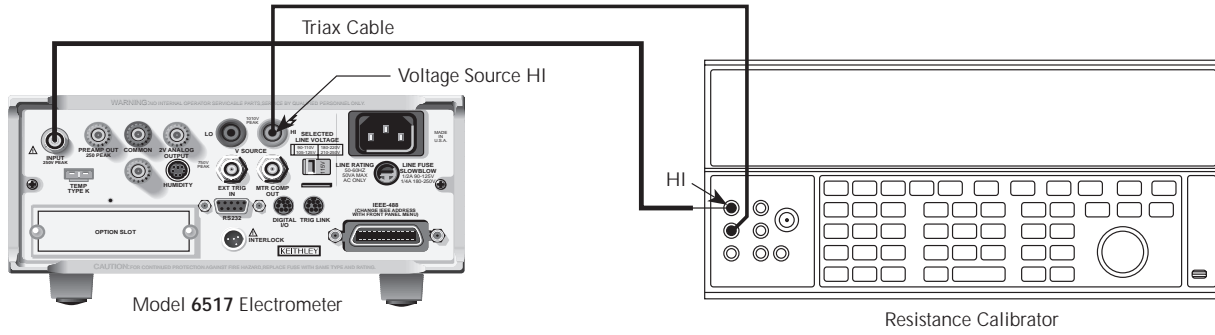
#### Step 4: Remove ground link

Remove the shorting link between COMMON and chassis ground on the rear panel. Floating COMMON will eliminate ground loops that might result in noise problems.

#### 2M $\Omega$ -200M $\Omega$ range verification

1. Connect the Model 6517A to the resistance calibrator, as shown in Figure 1-5.
2. Turn on the Model 6517A and the calibrator, and allow a one-hour warm-up period before making measurements.
3. Restore Model 6517A factory default conditions, as explained in paragraph 1.7.
4. Select the ohms function by pressing R.
5. Select the Model 6517A 2M $\Omega$  range, and make sure the filter is enabled.
6. Set the calibrator resistance to a nominal 1.9M $\Omega$  resistance value.
7. Place the voltage source in operate.
8. Make sure zero check is disabled, and allow the reading to settle. Verify that the displayed ohms reading is within limits for the selected range listed in Table 1-9.
9. Repeat steps 5 through 8 for the 20M $\Omega$  and 200M $\Omega$  ranges.
10. Turn off the Model 6517A voltage source, then disconnect the resistance calibrator from the Model 6517A.





**Figure 1-5**  
Connections for ohms verification ( $2M\Omega$ – $200M\Omega$  ranges)

**Table 1-9**  
Limits for ohms verification

Model 6517A range	Nominal resistance <sup>1</sup>	Reading limits <sup>2</sup> (1 year, 18°–28°C)
2M $\Omega$	1.9M $\Omega$	_____ to _____ M $\Omega$
20M $\Omega$	19M $\Omega$	_____ to _____ M $\Omega$
200M $\Omega$	100M $\Omega$	_____ to _____ M $\Omega$
2G $\Omega$	1G $\Omega$	_____ to _____ G $\Omega$
20G $\Omega$	10G $\Omega$	_____ to _____ G $\Omega$
200G $\Omega$	100G $\Omega$	_____ to _____ G $\Omega$
2T $\Omega$	1T $\Omega$	_____ to _____ T $\Omega$
20T $\Omega$	10T $\Omega$	_____ to _____ T $\Omega$
200T $\Omega$	100T $\Omega$	_____ to _____ T $\Omega$

<sup>1</sup> Resistance calibrator used for 2M $\Omega$ -200M $\Omega$  ranges. Model 5156 Calibration Standard used for 2G $\Omega$ -200G $\Omega$  ranges. Characterized resistance standards used for 2T $\Omega$ -200T $\Omega$  ranges. Standards must be characterized to uncertainty at least four times better than equivalent Model 6517A specifications and mounted in shielded test box. (See Figure 1-8.)

<sup>2</sup> Reading limits calculated from actual resistance value and Model 6517A specifications. See text.

**2G $\Omega$ -200G $\Omega$  range verification**

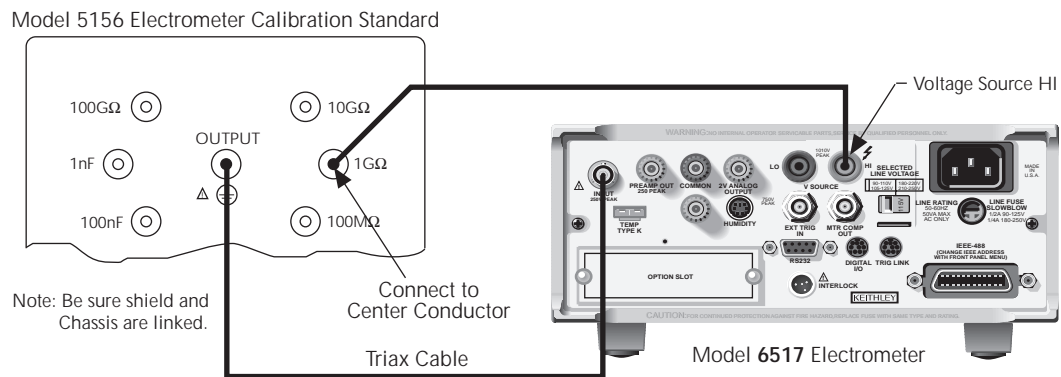
1. Connect the nominal 1G $\Omega$  characterized resistor from the Model 5156 Calibration Standard to the Model 6517A. (See Figure 1-6.)
2. Select the ohms function.
3. Place the voltage source in operate.
4. Select the 2G $\Omega$  range on the Model 6517A.
5. Make sure that zero check is disabled, and allow the reading to settle.
6. Verify that the displayed reading is within the calculated reading limits listed in Table 1-9.
7. Repeat steps 4 through 6 for the 20G $\Omega$  and 200G $\Omega$  ranges.
8. Turn off the voltage source, then disconnect the calibration standard from the Model 6517A.

**2T $\Omega$ -200T $\Omega$  range verification**

1. Connect the nominal 1T $\Omega$  characterized resistor to the Model 6517A. (See Figure 1-7.)

**NOTE**

Standard resistors must be characterized to an uncertainty at least four times better



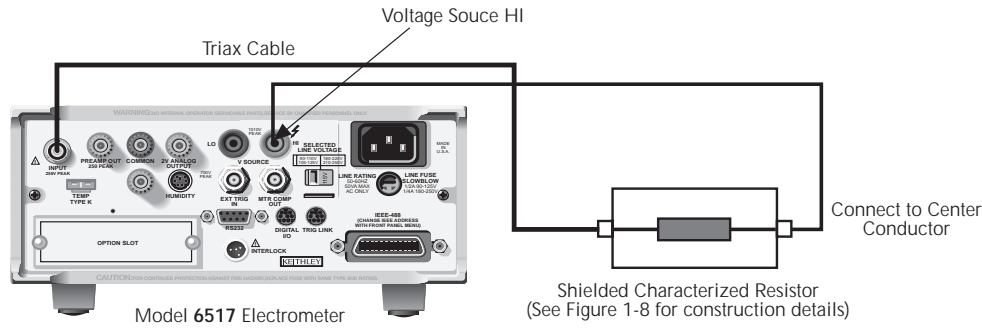
**Figure 1-6**  
Connections for ohms verification (2G $\Omega$ -200G $\Omega$  ranges)

than the equivalent Model 6517A accuracy specifications. These resistors must be mounted in specially shielded test fixtures to minimize noise. (See Figure 1-8 for details on test fixture construction.)

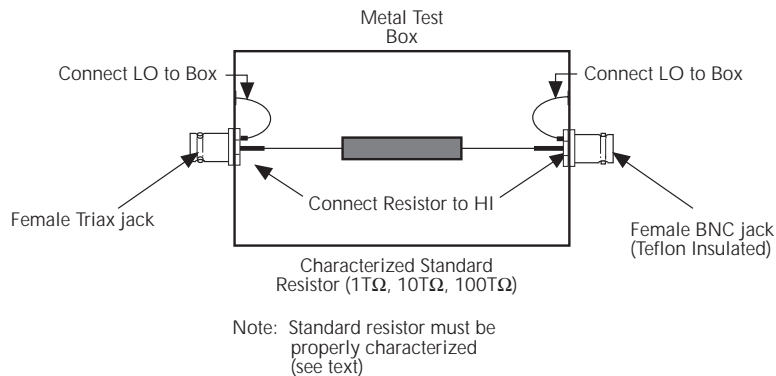
**WARNING**

**Hazardous voltage (400V) will be used in the following steps. Do not touch connecting cables or test leads while the voltage source is in operate.**

2. Select the 2T $\Omega$  range on the Model 6517A.
3. Place the voltage source in operate.
4. Make sure that zero check is disabled, and allow the reading to settle.
5. Verify that the displayed reading is within the calculated limits listed in Table 1-9.
6. Repeat steps 2 through 5 for the 20T $\Omega$  and 200T $\Omega$  ranges.
7. Turn off the voltage source, then disconnect the standard resistor from the Model 6517A.



**Figure 1-7**  
Connections for ohms verification ( $2T\Omega$ – $200T\Omega$  ranges)



**Figure 1-8**  
Shielded fixture construction

## 1.10 Voltage source verification

Voltage source output accuracy is checked by programming the voltage source to specific values and measuring the output voltage using a precision digital multimeter.

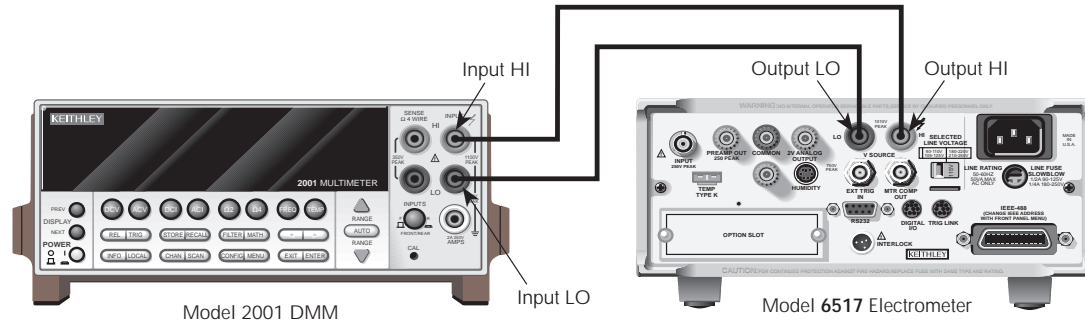
### WARNING

**Hazardous voltages will be used in the following steps. Use caution when working with hazardous voltages.**

Proceed as follows to check the accuracy of the voltage source.

1. Turn on the Model 6517A and the DMM, and allow both instruments to warm up for at least one hour before making measurements.

2. Set the DMM to the DCV function, and enable auto-ranging.
3. Temporarily short the ends of the DMM test leads together, then enable the DMM REL mode. Leave REL enabled for the remainder of the test.
4. With the Model 6517A voltage source in standby (turned off), connect the DMM to the Model 6517A V-SOURCE OUT jacks, as shown Figure 1-9. Be sure to connect Model 6517A output HI to the DMM input HI, and output LO to input LO as shown.
5. Program the Model 6517A voltage source for an output value of 0.000V, and place the voltage source in operate.
6. Verify that the DMM reading is within the limits shown in the first line of Table 1-10.
7. Repeat steps 5 and 6 for each voltage output value listed in Table 1-10.
8. Repeat the procedure for negative output voltages with the same magnitudes listed in Table 1-10.



**Figure 1-9**  
Connections for voltage source verification

**Table 1-10**  
Limits for voltage source verification

6517A programmed source output	Voltage source output limits (1 year, 18° to 28°C)
0.000V	0.01V to +0.01V
25.000V	24.9525 to 25.0475
50.000V	49.915V to 50.085V
75.000V	74.8775V to 75.1225V
100.000V	99.84V to 100.16V
250.00V	249.525V to 250.475V
500.00V	499.15V to 500.85
750.00V	748.775V to 751.225V
1000.00V	998.4V to 1001.6V

1. Output limits shown are based only on Model 6517A one-year accuracy specifications and do include DMM uncertainty.
2. Repeat procedure for negative output voltages of same magnitude.

### 1.11 Temperature verification

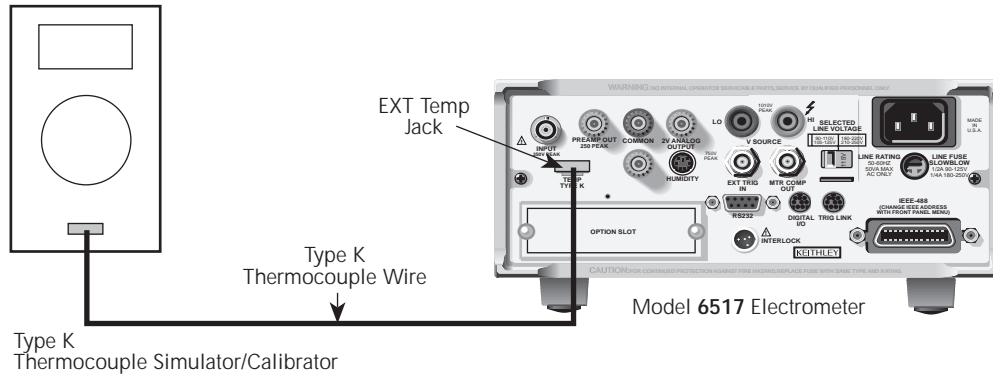
Accuracy of the Model 6517A temperature measurement function is checked by connecting a thermocouple calibrator to the Model 6517A and then verifying that the temperature reading is within required limits.

Proceed as follows:

1. Connect the type K thermocouple calibrator to the Model 6517A EXT TEMP jack, as shown in Figure 1-10.
2. Turn on the Model 6517A, and allow a one-hour warm-up period before making measurements.
3. Enable the Model 6517A external temperature display with the DISPLAY PREV key.
4. Set the thermocouple calibrator to -25°C, and allow the temperature reading to settle.
5. Verify that the Model 6517A temperature reading is within the limits stated in Table 1-11.
6. Repeat steps 6 and 7 for each calibrator temperature setting listed in Table 1-11.

**Table 1-11**  
Reading limits for temperature verification

Calibration temperature	Temperature reading limits (1 year, 18° to 28°C)
-25°C	-26.42°C to -23.58°C
0°C	-1.5°C to 1.5°C
50°C	48.35°C to 51.65°C
100°C	98.2°C to 101.8°C
150°C	148.05°C to 151.95°C



**Figure 1-10**  
Connections for temperature verification

## 1.12 Humidity verification

Humidity measurement accuracy is checked by applying an accurate 0-1V DC voltage to the Model 6517A and verifying that the humidity readings are within specified limits.

Proceed as follows:

1. With the power off, connect the DC calibrator to the Model 6517A HUMIDITY connector, as shown in Figure 1-11. Use short lengths of solid #22AWG copper wire and alligator clips to make the connections, and be sure to observe proper polarity (calibrator HI to HUMIDITY +V and calibrator LO to HUMIDITY -V).
2. Turn on the power to the Model 6517A and the calibrator, and allow a one-hour warm-up period before making measurements.
3. Select the Model 6517A humidity display with DISPLAY PREV key.
4. Set the DC calibrator output to +0.2500V.

5. Allow the reading to settle, then verify that the Model 6517A humidity reading is within the limits summarized in Table 1-12.
6. Repeat steps 4 and 5 for each of the voltage/humidity reading combinations summarized in Table 1-12.

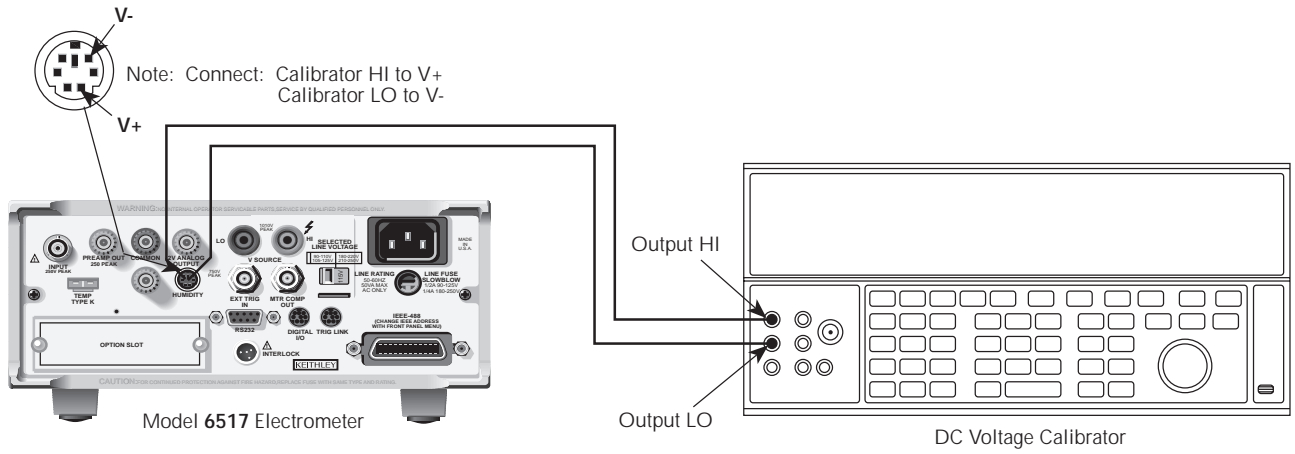
**Table 1-12**

Limits for humidity verification

Applied voltage	Humidity reading limits (1 year, 18° to 28° C)
0.0000V	0% to 1%
0.2500V	24% to 26%
0.5000V	49% to 51%
0.7500V	74% to 76%
1.0000V	99% to 101%

### CAUTION

**Do not exceed +2V input to the HUMIDITY jack, and be sure to observe proper polarity. Failure to do so may result in damage to the unit.**



**Figure 1-11**  
Connections for humidity verification

# 2

## Calibration

---

### 2.1 Introduction

This section gives detailed procedures for calibrating the Model 6517A. Basically, there are four parts to the comprehensive calibration procedure:

- Meter calibration (volts, amps, and coulombs)
- Temperature calibration
- Voltage source calibration
- Humidity calibration

Meter calibration requires accurate calibration equipment to supply precise DC voltages, DC currents, and charge values. Voltage source calibration requires an accurate DMM to measure DC voltages. Temperature calibration requires special temperature calibration equipment, while an accurate voltage source is needed for humidity calibration.

A single-point calibration feature is also available to allow you to calibrate a single function or range without having to perform the entire calibration procedure.

#### WARNING

**The procedures in this section are intended only for qualified service personnel. Do not attempt to perform these procedures unless you are qualified to do so.**

Section 2 includes the following information:

**2.2 Environmental conditions:** States the temperature and humidity limits for calibration.

**2.3 Warm-up period:** Discusses the length of time the Model 6517A should be allowed to warm up before calibration.

**2.4 Line power:** States the power line voltage limits when calibrating the unit.

**2.5 Recommended calibration equipment:** Summarizes all test equipment necessary for calibrating the Model 6517A.

**2.6 Calibration lock:** Explains how to unlock calibration using the CAL switch.

**2.7 Calibration errors:** Discusses front panel error messages that might occur during calibration and also explains how to check for errors over the bus.

**2.8 Front panel calibration:** Covers calibration of all Model 6517A functions from the front panel. Functions calibrated include volts, amps, coulombs, the voltage source, as well as the temperature and humidity functions.

**2.9 IEEE-488 bus calibration:** Details calibration of all instrument functions over the IEEE-488 bus.

**2.10 Single-point calibration:** Outlines the basic methods for calibrating only a single function or range instead of having to go through the entire calibration procedure.

**2.11 Programming calibration dates:** Covers the procedures for programming the calibration date and calibration due date.

**2.12 Calibration temperature difference:** Discusses how to determine the internal temperature difference.

## 2.2 Environmental conditions

Voltage and 20 $\mu$ A-20mA current calibration procedures should be performed at an ambient temperature of 23°  $\pm$ 5°C, and at a relative humidity of less than 70% unless otherwise noted. 20pA-2 $\mu$ A current and coulombs calibration should be performed at 23°  $\pm$ 3°C because of Model 5156 temperature restrictions.

### NOTE

If the instrument is normally used over a different ambient temperature range, calibrate the instrument at the center of that temperature range.

## 2.3 Warm-up period

The Model 6517A must be allowed to warm up for at least one hour before calibration. If the instrument has been subjected to temperature extremes (outside the range stated in paragraph 2.2), allow additional time for internal temperatures to stabilize. Typically, it takes one additional hour to stabilize a unit that is 10°C (18°F) outside the specified temperature range.

The calibration equipment should also be allowed to warm up for the minimum period specified by the manufacturer.

## 2.4 Line power

The Model 6517A should be calibrated while operating from a line voltage within the range specified by the LINE VOLTAGE switch on the rear panel, at a line frequency of 50 or 60Hz.

## 2.5 Recommended calibration equipment

Table 2-1 summarizes test equipment recommended for calibrating the various Model 6517A functions. Alternate equipment may be used as long as that equipment has specifications equal to or better than those listed in the table.

### NOTE

The Model 5156 Electrometer Calibration Standard is recommended for calibrating the 20pA-2 $\mu$ A amps ranges and all coulombs ranges. Alternate resistance and capacitance standards may be used as long as those standards are characterized to an uncertainty that is at least four times better than equivalent Model 6517A specifications.

### NOTE

Make all input low connections directly to the triax INPUT connector instead of COMMON to avoid calibration errors caused by internal voltage drops. Use the connecting methods shown in this section to avoid this problem.



**Table 2-1**  
Recommended calibration equipment

Mfg.	Model	Description	Specifications*
Fluke	5700A	Calibrator	±5ppm basic uncertainty <sup>1</sup> DC Voltage: 1.9V: ±7ppm 19V: ±5ppm 190V: ±7ppm DC current: 19µA: ±576ppm 190µA: ±103ppm 1.9mA: ±55ppm 19mA: ±55ppm
Keithley	5156	Electrometer Calibration Standard	100MΩ <sup>2</sup> 1GΩ 10GΩ 100GΩ 1nF 100nF
Keithley	2001	Multimeter	1000V range: ±47ppm <sup>3</sup> 200V range: ±41ppm
Keithley	8607	Dual banana plug cable	
Keithley	4801	Low-noise coax cable	
Keithley	7078-TRX-BNC	Triax-to BNC adapter BNC to dual banana plug adapter	
Keithley	237-ALG-2	Triax to alligator clips cable*	
Keithley	CAP-31	Triax shielding cap Banana plugs to clip leads 2, 1 in. lengths of solid #20AWG wire	
Omega	CL-307-K	Type K thermocouple simulator/calibrator	0°C (0mV), 100°C (4.095mV) ±0.04%

1. 90-day calibrator specifications shown include total absolute uncertainty at specified output.

2. Nominal values for calibration standards shown. Alternate standards may be used if those standards are characterized to uncertainty at least four times better than equivalent Model 6517A specifications.

3. 1-year multimeter specifications are for full-range input.

\*Short red and black clips together to make triax short.

## 2.6 Calibration lock

### 2.6.1 Unlocking calibration

Before performing calibration, you must first unlock calibration by momentarily pressing in on the recessed CAL switch. The instrument will display the following message:

```
CALIBRATION UNLOCKED  
Comprehensive cal can now be run
```

If you attempt calibration without performing the unlocking procedure, the following message will be displayed:

```
CALIBRATION LOCKED  
Press the CAL switch to unlock
```

### 2.6.2 IEEE-488 bus calibration lock status

You can determine the status of the calibration lock over the bus by using the appropriate query. To determine calibration lock status, send the following query:

```
:CAL:PROT:SWIT?
```

The instrument will respond with the calibration lock status:

```
0: comprehensive calibration locked  
1: comprehensive calibration unlocked
```

Refer to Section 3 for more details on calibration commands.

## 2.7 Calibration errors

The Model 6517A checks for errors after each calibration step, minimizing the possibility that improper calibration may occur due to operator error. The following paragraphs discuss both front panel and bus error reporting.

### 2.7.1 Front panel error reporting

If an error is detected during comprehensive calibration, the instrument will display an appropriate error message (see Appendix B).

### 2.7.2 IEEE-488 bus error reporting

You can detect errors over the bus by testing the state of EAV (Error Available) bit (bit 2) in the status byte. (Use the \*STB? query or serial polling to request the status byte.) If you wish to generate an SRQ (Service Request) on errors, send “\*SRE 4” to the instrument to enable SRQ on errors.

You can query the instrument for the type of error by using the appropriate calibration error query. The Model 6517A will respond with the error number and a text message describing the nature of the error. Paragraph 3.8 in Section 3 discusses error queries, and Appendix B summarizes calibration errors.

## 2.8 Front panel calibration

The front panel comprehensive calibration procedure calibrates meter functions (volts, amps, and coulombs) as well as the voltage source, and the temperature and humidity functions. Calibration should be performed at least once a year.

The procedures below will take you step-by-step through complete Model 6517A calibration from the front panel and include the following:

- Meter calibration (volts, amps, coulombs)
- Temperature calibration
- Voltage source calibration
- Humidity calibration

#### NOTE

If you wish to calibrate only a single function or range, refer to the single-point calibration procedures covered in paragraph 2.10.

### 2.8.1 Front panel calibration summary

Table 2-2 summarizes the front panel calibration procedure.

**Table 2-2**  
Front panel calibration summary

Step	Description	Equipment/connections
1	Warm-up, unlock calibration	None
2	Offset voltage adjustment	Triax shorting cap to INPUT jack
3	Bias current adjustment	Triax shielding cap to INPUT
4	Zero voltage calibration	Triax short to INPUT
5	+2V calibration	Voltage calibrator to INPUT
6	-2V calibration	Voltage calibrator to INPUT
7	+20V calibration	Voltage calibrator to INPUT
8	-20V calibration	Voltage calibrator to INPUT
9	+200V calibration	Voltage calibrator to INPUT
10	-200V calibration	Voltage calibrator to INPUT
11	Zero current calibration	Triax shield to INPUT
12	+20pA calibration	Voltage/cal unit to INPUT
13	-20pA calibration	Voltage/cal unit to INPUT
14	+200pA calibration	Voltage/cal unit to INPUT
15	-200pA calibration	Voltage/cal unit to INPUT
16	+2nA calibration	Voltage/cal unit to INPUT
17	-2nA calibration	Voltage/cal unit to INPUT
18	+20nA calibration	Voltage/cal unit to INPUT
19	-20nA calibration	Voltage/cal unit to INPUT
20	+200nA calibration	Voltage/cal unit to INPUT
21	-200nA calibration	Voltage/cal unit to INPUT
22	2 $\mu$ A calibration	Voltage/cal unit to INPUT
23	-2 $\mu$ A calibration	Voltage/cal unit to INPUT
24	20 $\mu$ A calibration	Current calibrator to INPUT
25	-20 $\mu$ A calibration	Current calibrator to INPUT
26	200 $\mu$ A calibration	Current calibrator to INPUT
27	-200 $\mu$ A calibration	Current calibrator to INPUT
28	+2mA calibration	Current calibrator to INPUT
29	-2mA calibration	Current calibrator to INPUT
30	+20mA calibration	Current calibrator to INPUT
31	-20mA calibration	Current calibrator to INPUT
32	2nC zero calibration	Voltage/cal unit to INPUT
33	+2nC calibration	Voltage/cal unit to INPUT
34	-2nC calibration	Voltage/cal unit to INPUT
35	20nC zero calibration	Voltage/cal unit to INPUT
36	+20nC calibration	Voltage/cal unit to INPUT
37	-20nC calibration	Voltage/cal unit to INPUT
38	200nC zero calibration	Voltage/cal unit to INPUT
39	+200nC calibration	Voltage/cal unit to INPUT
40	-200nC calibration	Voltage/cal unit to INPUT
41	2 $\mu$ C zero calibration	Voltage/cal unit to INPUT
42	+2 $\mu$ C calibration	Voltage/cal unit to INPUT
43	-2 $\mu$ C calibration	Voltage/cal unit to INPUT
44	0°C temperature calibration	Thermocouple cal to EXT TEMP
45	100°C temperature calibration	Thermocouple cal to EXT TEMP
46	0V 100V range voltage source cal	DMM to V SOURCE OUT
47	40V voltage source calibration	DMM to V SOURCE OUT
48	100V voltage source calibration	DMM to V SOURCE OUT

**Table 2-2**  
Front panel calibration summary (cont.)

Step	Description	Equipment/connections
49	-100V voltage source calibration	DMM to V SOURCE OUT
50	0V 1000V range voltage source cal	DMM to V SOURCE OUT
51	400V voltage source calibration	DMM to V SOURCE OUT
52	1000V voltage source calibration	DMM to V SOURCE OUT
53	-1000V voltage source calibration	DMM to V SOURCE OUT
54	Humidity 0V calibration	DC calibrator to HUMIDITY
55	Humidity 0.5V calibration	DC calibrator to HUMIDITY
56	Humidity 1V calibration	DC calibrator to HUMIDITY

## 2.8.2 Front panel calibration procedure

The paragraphs that follow will take you step-by-step the comprehensive calibration procedure, which calibrates all Model 6517A functions, including volts, ohms, amps, the voltage source, temperature, and humidity.

### Step 1: Prepare the Model 6517A for Calibration

1. With the power off, connect the Model 5156 Electrometer Calibration Standard to the rear panel DIGITAL I/O jack using the supplied cable (see Figure 2-1). Note that the calibration unit is used to calibrate the 20pA - 2μA amps ranges as well as all coulombs ranges.

#### NOTE

The calibration standard must be connected to the Model 6517A DIGITAL I/O port in order to operate properly. Do not connect any equipment except the Model 5156 Calibration Standard to the Model 6517A DIGITAL I/O port during calibration. Other equipment may be affected by digital signals present during calibration.

2. Turn on the power, and allow the Model 6517A to warm up for at least one hour before performing calibration.
3. Unlock comprehensive calibration by briefly pressing in on the recessed front panel CAL switch, and verify that the following message is displayed:

```
CALIBRATION UNLOCKED
Comprehensive cal can now be run
```

4. Enter the front panel calibration menu as follows:
  - a. From normal display, press MENU. The instrument will display the following:

```
MAIN MENU
SAVESETUP COMMUNICATION CAL
```

- b. Select the CAL/CAL-OPT/CONTROL menu. The instrument will then prompt you as to whether or not you intend to use the calibration standard:

```
USE CAL OPTION
YES NO
```

- c. Select YES, then press ENTER followed by EXIT.

#### NOTE

The calibration option must be enabled in order to use the recommended calibration standard. See paragraph 2.11 for details.

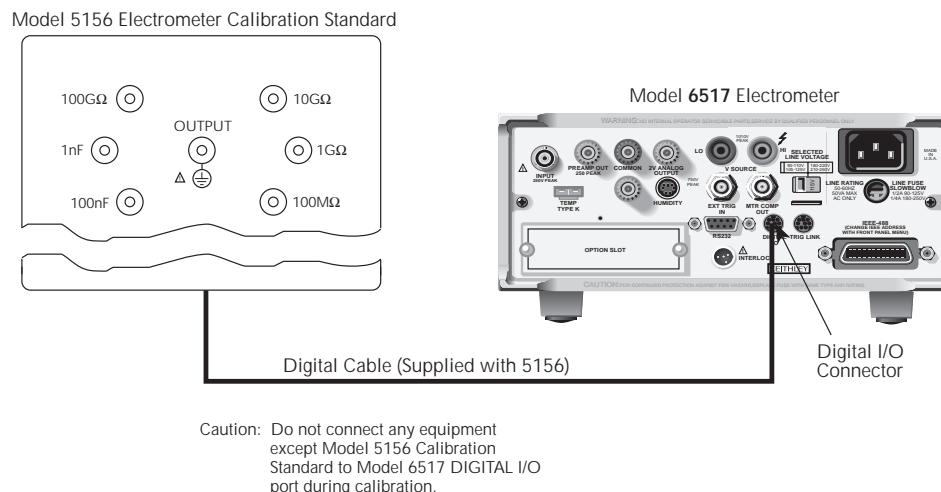
- d. The unit will then display the following prompt:

```
PERFORM CALIBRATION
COMPREHENSIVE POINT-CALS ►
```

- e. Select COMPREHENSIVE, then press ENTER.

5. At this point, the instrument will display the following message to indicate that you have chosen the full calibration procedure:

```
FULL CALIBRATION
Press ENTER to continue; EXIT to ►
◀ abort calibration sequence
```



**Figure 2-1**  
Calibration unit connections

### Step 2: Offset Calibration

1. Press ENTER. The instrument will display the following prompt.

CONNECT TRIAX SHORT  
ENTER to continue; EXIT to abort

2. Connect the shorted triax cable (connect red and black clips together) to the instrument INPUT jack.
3. Press ENTER. The instrument will then begin voltage offset calibration. While calibration is in progress, the following will be displayed:

Performing V offset calibration

4. When the voltage offset calibration step is completed, the following message will be displayed:

CONNECT TRIAX CAP  
ENTER to continue, EXIT to abort

5. Disconnect the triax short from the INPUT jack, and connect the triax shielding (non-shorting) cap to the INPUT jack in its place.
6. Press ENTER to begin the bias current calibration step. During this step, the instrument will display:

Performing I Bias calibration

### Step 3: Volts Calibration

1. Remove the triax shielding cap from the INPUT jack, and connect the DC voltage calibrator to the INPUT jack in its place, as shown in Figure 2-2. Note that these connections are made using a low-noise coax cable, a triax-to-BNC adapter, and a BNC-to-dual banana plug adapter.
2. Following the zero check calibration step, the instrument will prompt you to connect 0V DC:

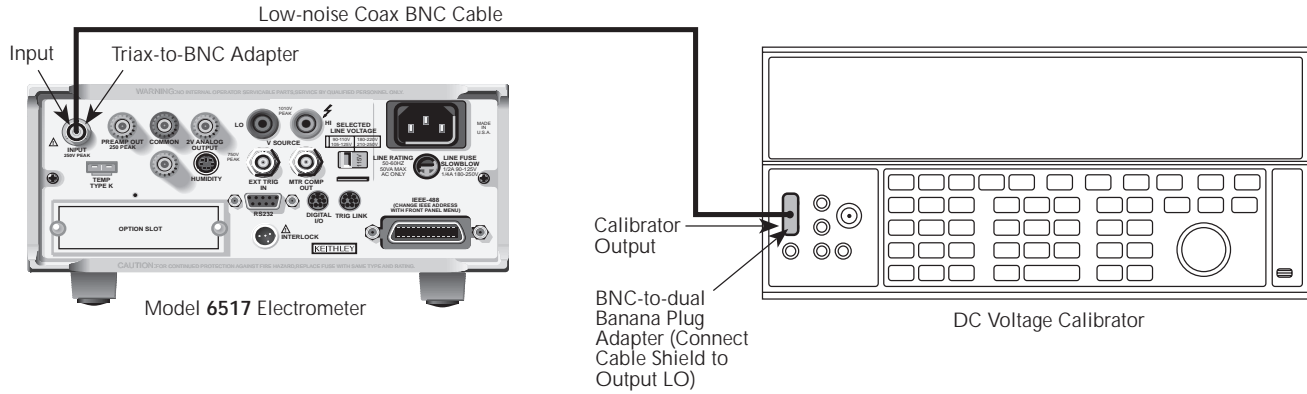
CONNECT 0 V  
ENTER to continue; EXIT to abort

3. Set the DC voltage calibrator output to 0.00000V DC, and allow a short time period for settling.
4. Press ENTER to continue. During 0V DC calibration, the Model 6517A will display the following:

Performing 0V calibration

5. Next, the unit will prompt for a 1.9V DC input:

CONNECT 2.000000 V  
ENTER to continue; EXIT to abort



**Figure 2-2**  
Connections for DC volts calibration

- Set the output of the DC voltage calibrator to exactly +1.900000V, then press the Model 6517A ENTER key. The instrument will then prompt for the exact calibration value:

1.9000000 V

Use ▲, ▼, ◀, ▶, ENTER, EXIT or INFO

- If necessary, use the range and cursor keys to set the displayed value to the exact calibrator voltage value.

**NOTE**

For optimum accuracy, it is recommended that you use the default values throughout the entire calibration procedure.

- After setting the calibration value, press ENTER to continue. During this step, the instrument will display the following:

Performing 2 V Calibration

- Next, the unit will prompt you to apply -1.9V:

CONNECT -2.000000 V

ENTER to continue; EXIT to abort

- Set the DC voltage calibrator output to exactly -1.9000000V DC, then press ENTER. Again, the unit will prompt you for the actual applied voltage:

-1.9000000 V

ENTER to continue; EXIT to abort

- Again, set the displayed value to agree with the calibrator voltage, then press ENTER. During this step, the unit will display the following:

Performing -2V Calibration

- Repeat steps 5 through 11 for 20V and 200V ranges using the values summarized in Table 2-3. After performing all volts calibration points, continue with amps calibration detailed below.

**Table 2-3**

Volts calibration summary

6517A range	Applied calibration voltage	Comments
—	0.0000000V DC	Volts zero cal
2V	+1.9000000V DC	Positive 95% of full range
2V	-1.9000000V DC	Negative 95% of full range
20V	+19.0000000V DC	Positive 95% of full range
20V	-19.0000000V DC	Negative 95% of full range
200V	+190.000000V DC	Positive 95% of full range
200V	-190.000000V DC	Negative 95% of full range

**Step 4: Amps Calibration**

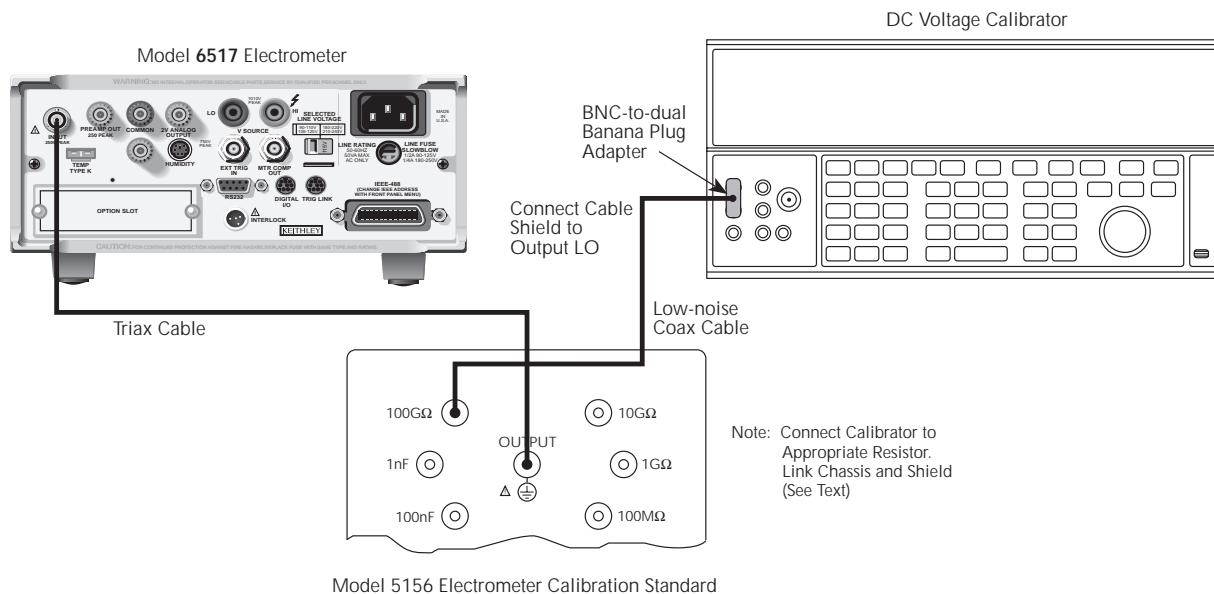
- At this point, the Model 6517A will display the following message:

CONNECT TRIAX CAP

ENTER to continue; EXIT to abort

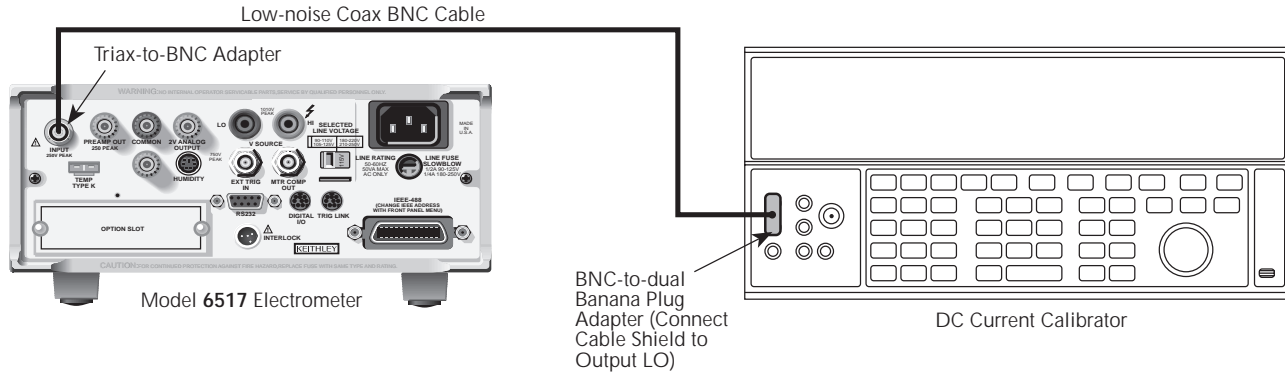
- Connect the triax shielding cap to the INPUT jack.
- Press the Model 6517A ENTER key. During this calibration step, the instrument will display the following:

Performing 0 A Calibration



**Figure 2-3**  
Connections for 20pA–2µA range calibration

4. Connect the Model 5156 Electrometer Calibration Standard and the DC voltage calibrator to the Model 6517A INPUT jack, as shown in Figure 2-3. Initially, make connections to the 100GΩ resistance in the standards box.
  5. After the zero current calibration step, the instrument will prompt you as follows:  
  
CONNECT 2V to 100G  
ENTER to continue; EXIT to abort
  6. Set the DC voltage calibrator to exactly 1.900000V DC. Make sure the 100GΩ resistor in the calibration standard is connected, then press the Model 6517A ENTER key. The instrument will prompt for the exact calibration value:  
  
1.9000000 V  
Use ▲, ▼, ◀, ▶, ENTER,EXIT or INFO
- NOTE**
- For all calibration steps that involve the Model 5156, you can set calibration values in either one of two ways: (1) set the calibrator output to agree with the displayed value, or (2) adjust the display to agree with the calibrator value.
7. Adjust the calibrator voltage to agree with the exact display value, then press the ENTER key. During this step, the instrument will display the following:  
  
Performing 20 pA cal
  8. Next, the instrument will prompt you as follows:  
  
CONNECT -2V to 100G  
ENTER to continue; EXIT to abort
  9. Press the Model 6517A ENTER key. The instrument will prompt for the exact calibration value:  
  
-1.9000000 V  
Use ▲, ▼, ◀, ▶, ENTER,EXIT or INFO
  10. Set the calibrator output to the display value, then press the ENTER key. The unit will display the following during this calibration step:  
  
Performing -20 pA Calibration
  11. Repeat steps 5 through 10 for the 200pA through 2µA ranges using the voltages and resistance standards summarized in Table 2-4.
  12. Disconnect the calibration standard and voltage calibrator from the instrument, and connect the DC current calibrator directly to the Model 6517A INPUT jack (see Figure 2-4).
  13. At this point, the Model 6517A will display the following:  
  
CONNECT 19.00000 µA  
ENTER to continue; EXIT to abort



**Figure 2-4**  
Connections for 20µA–20mA range calibration

**Table 2-4**  
Amps calibration summary (20pA–2µA ranges)

6517A range	Calibrator voltage	Resistance <sup>1</sup> standard	Nominal <sup>2</sup> current
—	0.00000V	100GΩ	0pA
20pA	1.900000V	100GΩ	19pA
20pA	-1.900000V	100GΩ	-19pA
200pA	1.900000V	10GΩ	190pA
200pA	-1.900000V	10GΩ	-190pA
2nA	1.900000V	1GΩ	1.9nA
2nA	-1.900000V	1GΩ	-1.9nA
20nA	1.900000V	100MΩ	19nA
20nA	-1.900000V	100MΩ	-19nA
200nA	19.00000V	100MΩ	190nA
200nA	-19.00000V	100MΩ	-190nA
2µA	190.0000V	100MΩ	1.9µA
2µA	-190.0000V	100MΩ	-1.9µA

<sup>1</sup> Actual resistance standard value determined from calibration data supplied with standard.

<sup>2</sup> Actual calibration current :  $I = V/R$ , where  $V$  is the calibration voltage, and  $R$  is the actual resistance standard value. When using the Model 5156 Electrometer Calibration Standard, the Model 6517A automatically calculates the actual current from the actual standard value and the calibrator voltage.

14. Press the Model 6517A ENTER key. The unit will prompt for the exact calibration value:

19.000000 µA  
Use ▲, ▼, ◀, ▶, ENTER, EXIT, or INFO

15. Set the calibrator output to exactly +19.000000µA DC, make certain that the displayed value agrees with the applied current, then press the ENTER key. During this calibration phase, the unit will display the following:

Performing 20 µA cal

16. After this step has been completed, the instrument will prompt for the next calibration value:

CONNECT -20.00000 µA  
ENTER to continue; EXIT to abort

17. Set the calibrator output to exactly -19.00000µA DC, then press the Model 6517A ENTER key. The unit will then display the actual calibration value:

-19.000000 µA  
Use ▲, ▼, ◀, ▶, ENTER, EXIT, or INFO

18. If necessary, adjust the displayed value to agree with the calibrator current, then press the ENTER key. During this calibration step, the unit will display the following message:

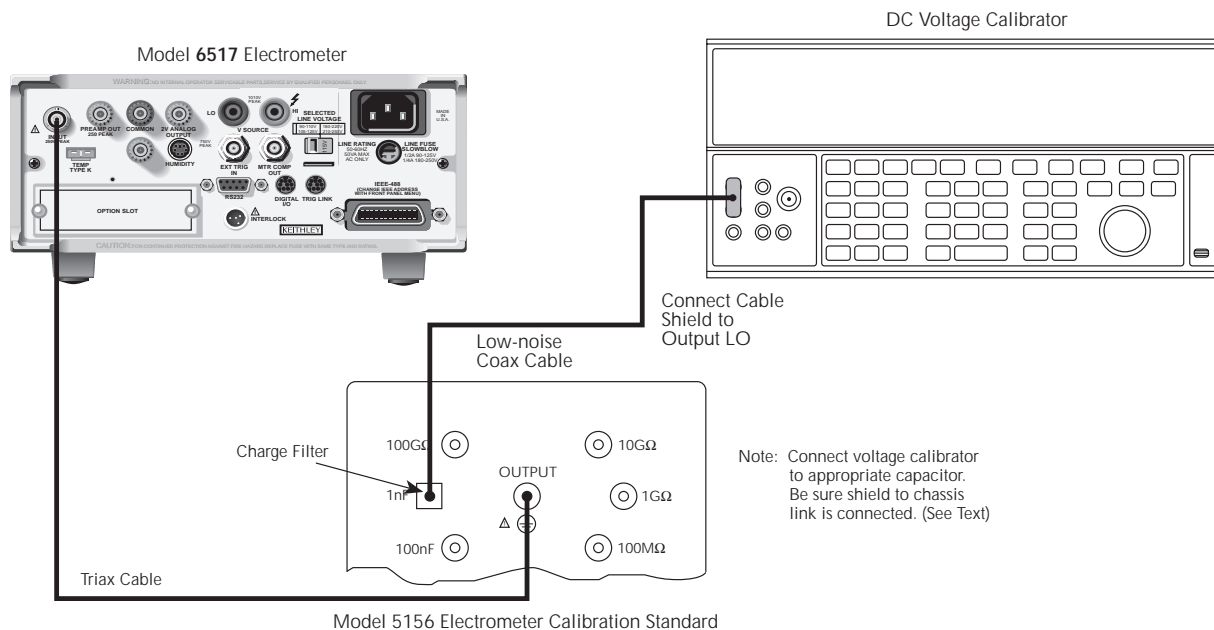
Performing -20 µA cal

19. Repeat steps 13 through 18 for the 200µA through 20mA ranges using the calibrator current values summarized in Table 2-5.

**Table 2-5**  
Amps calibration summary (20µA-20mA ranges)

6517A range	Calibration current
20µA	19.00000µA
20µA	-19.00000µA
200µA	190.0000µA
200µA	-190.0000µA
2mA	1.900000mA
2mA	-1.900000mA
20mA	19.00000mA
20mA	-19.00000mA





**Figure 2-5**  
Connections for coulombs calibration

**Step 5: Coulombs Calibration**

1. Connect the calibration standard and DC voltage calibrator to the Model 6517A INPUT jack, as shown in Figure 2-5. Initially, make connections to the 1nF capacitor in the standards box.
2. Set the output voltage of the DC calibrator to 0.00000V.
3. Press the ENTER key to begin zero check A calibration. During this step, the instrument will display:  
Performing 2nC zero check A cal
4. After zero cal, the instrument will display the following:  
CONNECT 2V to 1000pF  
ENTER to continue; EXIT to abort
5. Press the ENTER key, and note that the instrument displays the actual calibration value:  
+1.9000000 V  
Use ▲, ▼, ◀, ▶, ENTER,EXIT or INFO
6. Set the DC calibrator voltage to +1.9000000V DC. If necessary, set the displayed calibration value to agree with the actual calibrator voltage, then press the ENTER key. During this step, the instrument will display the following:  
Performing 2 nC cal

7. Set the calibrator output to 0V, then press the ENTER key to automatically perform 2nC zero check B calibration.
8. After zero check calibration, the instrument will prompt you for the next calibration step:  
CONNECT -2V to 1000pF  
ENTER to continue; EXIT to abort
9. Set the DC voltage calibrator to -1.900000V, and allow sufficient time for settling.
10. Press the ENTER key, and note that the instrument displays the exact calibration value:  
-1.9000000 V  
Use ▲, ▼, ◀, ▶, ENTER,EXIT or INFO
11. If necessary, adjust the display to agree with the exact calibration value.
12. Press the Model 6517A ENTER key. During this calibration phase, the instrument will display the following:  
Performing -2nC cal
13. Repeat steps 4 through 12 for the remaining coulombs ranges using the voltage values and capacitance standards values summarized in Table 2-6.

**Table 2-6**  
Coulombs calibration summary

6517A range	Calibration voltage	Standard <sup>1</sup> capacitance	Nominal <sup>2</sup> charge
2nC	1.900000V	1nF	1.9nC
2nC	-1.900000V	1nF	-1.9nC
20nC	19.00000V	1nF	19nC
20nC	-19.00000V	1nF	-19nC
200nC	1.900000V	100nF	190nC
200nC	-1.900000V	100nF	-190nC
2μC	19.00000V	100nF	1.9μC
2μC	-19.00000V	100nF	-1.9μC

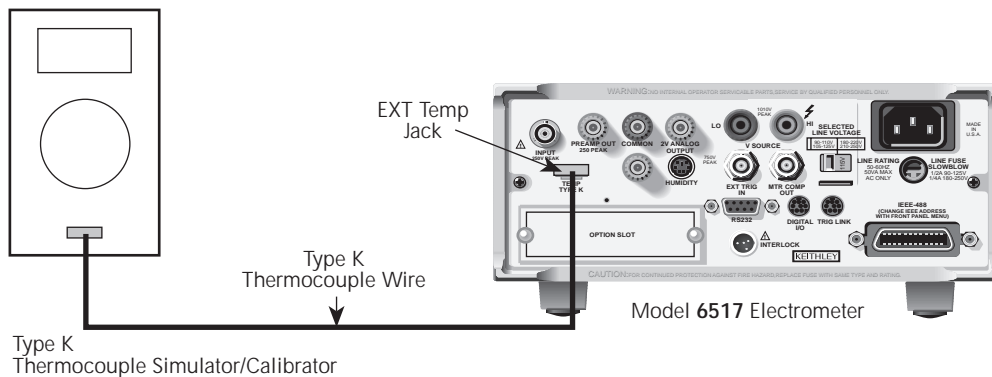
<sup>1</sup>Nominal capacitance standard shown. Refer to calibration data for actual value.

<sup>2</sup>Charge calculated from:  $Q = CV$ , where C is capacitance standard value, and V is the calibrator voltage. When using the Model 5156 Electrometer Calibration Standard, the Model 6517A automatically calculates the charge from the actual capacitance value and the applied calibrator voltage.

**Step 6: Temperature Calibration**

1. Connect the thermocouple calibrator to the Model 6517A EXT TEMP jack, as shown in Figure 2-6.
2. At the end of the coulombs calibration phase, the instrument will prompt you for the first temperature calibration point:

CONNECT 0V/0°C  
ENTER to continue; EXIT to abort



**Figure 2-6**  
Connections for temperature calibration

3. Set the thermocouple calibrator output to 0°C (0mV), then press the Model 6517A ENTER key. During this step, the instrument will display the following:

Performing 0 V Temp Calibration

4. Next, the instrument will prompt you for the 100°C (4.095mV) calibration point:

CONNECT 4.095mV/100°C

5. Set the thermocouple calibrator output to 100°C, then press the Model 6517A ENTER key. During this step, the instrument will display the following message:

Performing 4.095mV Temp Calibration

**Step 7: Voltage Source Calibration**

**WARNING**

**Hazardous voltages will be present when performing the following steps. Avoid touching terminals while performing these procedures.**

1. After temperature calibration has been completed, the instrument will prompt you to connect the voltmeter to the voltage source output jacks:

V-SOURCE CALIBRATION  
Connect Vsource to voltmeter

2. Select the DCV function and the auto-range mode on the DMM.

- Temporarily short the ends of the DMM test leads, then enable the DMM REL mode. Leave REL enabled for the remainder of the tests.
- Connect the DMM to the V SOURCE OUT jacks, as shown in Figure 2-7.
- Press ENTER. The Model 6517A will prompt you for 0V output:

V-SOURCE 0: 100V RNG  
Press ENTER to output 0V

- Press ENTER, and note that the instrument prompts for the actual DMM reading:

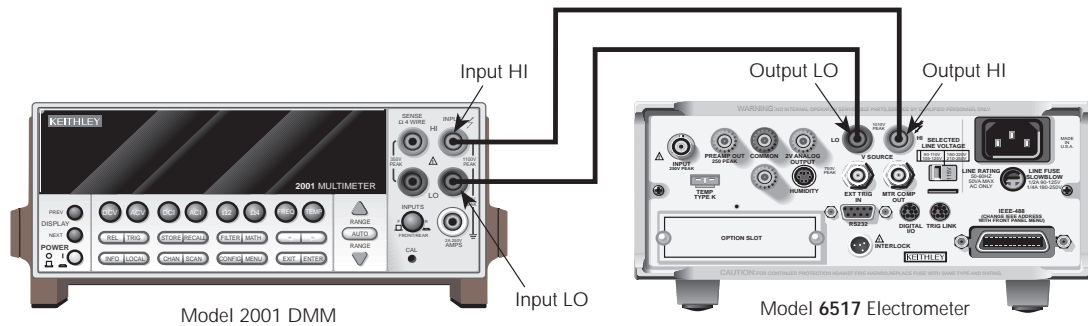
DMM RDG: +0.00000 V  
Use ▲, ▼, ◀, ▶, ENTER, EXIT or INFO

- Adjust the Model 6517A display so that it agrees exactly with the voltage reading on the DMM, then press the ENTER key.
- Repeat steps 6 and 7 for each voltage source output value summarized in Table 2-7. For each step, be sure to adjust the Model 6517A display to agree exactly with the DMM reading.

**Table 2-7**  
Voltage source calibration summary

Nominal output	Display prompt	Comments
0V	DMM RDG: +0.00000 V	100V range calibration
+40V	DMM RDG: +40.0000 V	
+100V	DMM RDG: +100.0000 V	
-100V	DMM RDG: -100.0000 V	
0V	DMM RDG: 0.00000 V	1000V range calibration
+400V	DMM RDG: +400.000 V	
+1000V	DMM RDG: +1000.000 V	
-1000V	DMM RDG: -1000.000 V	

NOTE: For each calibration step, adjust the displayed value to agree with the DMM reading.



**Figure 2-7**  
Connections for voltage source calibration

**Step 8: Humidity Calibration**

1. At the end of the voltage source calibration phase, the instrument will prompt you for humidity calibration:

HUMIDITY CALIBRATION  
Connect 0 V to humidity input

2. Connect the DC voltage calibrator to the rear panel HUMIDITY jack, as shown in Figure 2-8.
3. Set the DC calibrator output to 0.00000V, then press the Model 6517A ENTER key.
4. Repeat steps 2 and 3 for 0.5V and 1V input, as summarized in Table 2- 8.

**Table 2-8**  
*Humidity calibration summary*

Calibration point	Calibrator voltage
0V	0.00000V
0.5V	0.50000V
1V	1.00000V

**Step 9: Enter Calibration Dates**

1. At the end of humidity calibration steps, the unit will prompt you to enter the calibration date:

CAL DATE: mm/dd/yy

Note that the present date is used as the default displayed date, which is displayed in mm (month), dd (date), yy (year) format.

2. Change the displayed date to today's date, then press the ENTER key. You will then be given an opportunity to confirm or change your selection.
3. The unit will then prompt for the next calibration date:

NEXT CAL: mm/dd/yy

The default displayed next calibration date is one year from today's date and is displayed in mm (month), dd (date), yy (year) format.

4. Set the next calibration date to the desired value, then press ENTER. Again, you will be given the opportunity to confirm or change the date.

**Step 10: Complete Calibration**

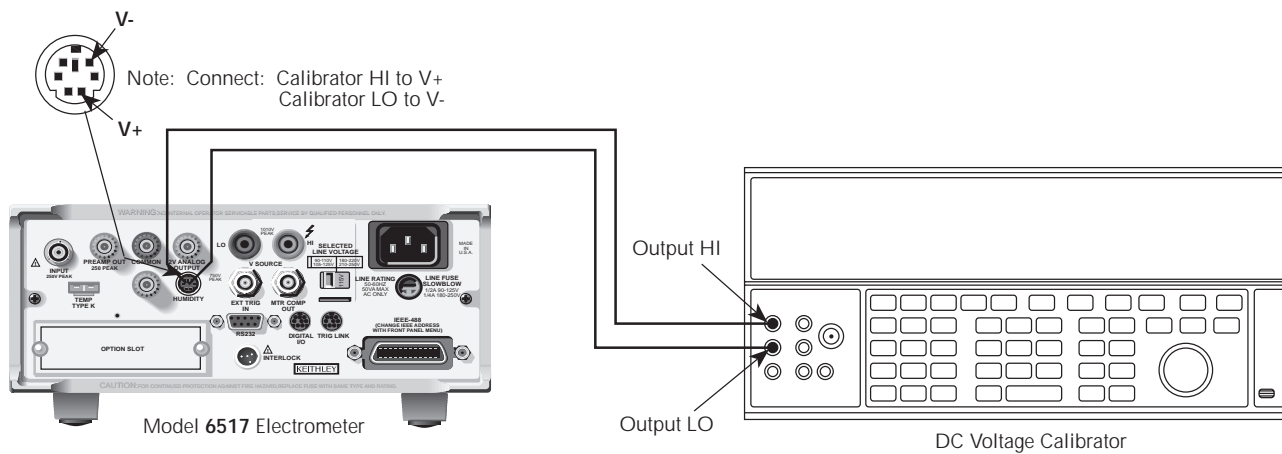
At the end of a successful calibration procedure, the instrument will display the following:

CALIBRATION SUCCESS  
ENTER to save; EXIT to abort

As displayed, press the ENTER key to save new calibration constants, or press EXIT to abort the calibration procedure.

**NOTE**

If you abort calibration, constants derived during the present calibration procedure will not be saved, and previous calibration values will be retained.



**Figure 2-8**  
*Connections for humidity calibration*

## 2.9 IEEE-488 bus calibration

### 2.9.1 Calibration commands

Refer to Section 3 or Appendix C for a complete listing of calibration commands. Section 3 also provides a detailed discussion of each command.

### 2.9.2 IEEE-488 bus comprehensive calibration procedure

Follow the procedure outlined below to perform comprehensive calibration over the IEEE-488 bus. The bus commands and appropriate parameters are separately summarized for each step.

#### Procedure

##### Step 1: Prepare the Model 6517A for Calibration

1. Connect the Model 6517A to the IEEE-488 bus of the computer using a shielded IEEE-488 cable such as the Keithley Model 7007.
2. Connect the calibration standard to the Model 6517A DIGITAL I/O jack (see Figure 2-1).

#### NOTE

The calibration standard must be connected to the DIGITAL I/O port in order to operate properly. Do not connect any equipment except the Model 5156 Electrometer Calibration Standard to the Model 6517A DIGITAL I/O port during calibration. Digital signals present during calibration may affect other equipment.

3. Turn on the power, and allow the Model 6517A to warm up for at least one hour before performing calibration.
4. Unlock calibration by briefly pressing in on the recessed front panel CAL switch, and verify that the following message is displayed:

CALIBRATION UNLOCKED  
Comprehensive cal can now be run

#### NOTE

You can query the instrument for the state of the comprehensive CAL switch by using the following query:

```
:CAL:PROT:SWIT?
```

A returned value of 1 indicates that calibration is locked, while a returned value of 0 shows that calibration is unlocked.

5. Make sure the primary address of the Model 6517A is the same as the address specified in the program you will be using to send commands. (Use the MENU key and the COMMUNICATION menu to access the IEEE-488 address.)

##### Step 2: Offset Calibration

Perform the steps below to perform the various offset calibration steps. Table 2-9 summarizes these steps.

1. Connect the shorted triax cable (connect red and black clips) to the instrument INPUT jack.
2. Send the following command over the bus:

```
:CAL:UNPR:VOFF
```

Wait until the instrument completes this step before continuing. (See paragraph 3.9.)

3. Disconnect the triax shorting cap from the INPUT jack, and connect the triax shielding (non-shorting) cap to the INPUT jack in its place.
4. Send the following command to the instrument:

```
:CAL:UNPR:IOFF
```

Wait until the instrument completes this step before continuing.

##### Step 3: Initiate Calibration

Send the following command over the bus to initiate calibration:

```
:CAL:PROT:INIT
```

**Table 2-9**  
*Offset calibration steps*

Step	Bus command	Connections*
Offset voltage	:CAL:UNPR:VOFF	Triax shorting cable
Bias current	:CAL:UNPR:IOFF	Triax shielding cap

\* Connect indicated triax cap or cable to INPUT jack.

**Step 4: Volts Calibration**

Perform the steps below to calibrate the Model 6517A volts function. Table 2-10 summarizes these steps.

1. Remove the triax shielding cap from the INPUT jack, and connect the DC voltage calibrator to the INPUT jack in its place (see Figure 2-2).
2. Set the DC voltage calibrator output to 0.00000V DC, and allow a short time period for settling.
3. Send the following command to the instrument:

:CAL:PROT:VZERO2

**NOTE**

Throughout the entire calibration procedure, be sure to allow the instrument to complete each command before sending the next one. See paragraph 3.9 in Section 3 for information on how to determine when each command has been completed.

4. Set the calibrator output voltage to +1.900000V, and allow time for settling.

5. Send the following command to the instrument:

:CAL:PROT:V2 1.9

**NOTE**

If you are using calibration values other than those given, be sure to change command parameters accordingly. However, for optimum accuracy, it is recommended that you use the stated calibration values throughout the entire calibration procedure.

6. Set the calibrator output voltage to -1.90000V, and allow for settling time.

7. Send the following command:

:CAL:PROT:VN2 -1.9

8. Repeat steps 3 through 7 for the +20V, -20V, +200V, and -200V steps using the calibrator voltages and commands summarized in Table 2-10. For each step, be sure to set the calibrator voltage properly, and use the correct bus command.

**Table 2-10**  
*IEEE-488 bus volts function calibration summary*

Volts calibration step	Calibrator voltage	Bus commands*
2V range zero	0.000000V DC	:CAL:PROT:VZERO2
+2V step	+1.900000V DC	:CAL:PROT:V2 1.9
-2V step	-1.900000V DC	:CAL:PROT:VN2 -1.9
20V range zero	0.000000V DC	:CAL:PROT:VZERO20
+20V step	+19.00000V DC	:CAL:PROT:V20 19
-20V step	-19.00000V DC	:CAL:PROT:VN20 -19
200V range zero	0.000000V DC	:CAL:PROT:VZERO200
+200V step	+190.0000V DC	:CAL:PROT:V200 190
-200V step	-190.0000V DC	:CAL:PROT:VN200 -190

\*Bus command parameters based on recommended calibrator voltages. Substitute appropriate numeric parameter if using different calibrator voltages.

*Step 5: Amps Calibration*

Perform the following steps to calibrate the amps function. Table 2-11 and Table 2-12 summarize these steps.

1. Connect the triax shielding cap to the INPUT jack.
2. Send the following commands to the instrument:

```
:CAL:PROT:AZERO20P
:CAL:PROT:AZERO200P
:CAL:PROT:AZERO2N
:CAL:PROT:AZERO20N
:CAL:PROT:AZERO200N
:CAL:PROT:AZERO2U
:CAL:PROT:AZERO20U
:CAL:PROT:AZERO200U
:CAL:PROT:AZERO2M
:CAL:PROT:AZERO20M
```

3. Connect the Model 5156 Calibration Standard and the DC voltage calibrator to the Model 6517A INPUT jack (see Figure 2-3). Initially, make connections to the 100GΩ resistance in the standards box.
4. Set the DC voltage calibrator to exactly +1.900000V DC, then send the following command to the instrument:

```
:CAL:PROT:A20PCARD 1.9
```

5. Set the DC voltage calibrator output to -1.900000V DC, then send the following command to the unit:

```
:CAL:PROT:AN20PCARD -1.9
```

6. Repeat steps 4 and 5 for the 200pA through 2μA ranges using the calibration values summarized in Table 2-11. For each step, be sure to connect the appropriate resistance, set the DC calibrator voltage as required, and use the correct command.
7. Disconnect the calibration standard and voltage calibrator, and connect the triax cap to the INPUT jack.
8. Send the following command:
 

```
:CAL:PROT:AZERO20U
:CAL:PROT:AZERO200U
:CAL:PORT:AZERO2M
:CAL:PROT:AZERO20M
```
9. Connect the DC current calibrator to the INPUT jack.
10. Set the DC current calibrator output to +19.00000μA, then send the following command:
 

```
:CAL:PROT:A20U 19E-6
```
11. Set the DC current calibrator output to -19.00000μA, then send the following command:
 

```
:CAL:PROT:AN20U -19E-6
```
12. Repeat steps 10 and 11 for the 200μA through 20mA ranges using the calibration currents and commands summarized in Table 2-12.

**Table 2-11**  
IEEE-488 bus amps calibration summary (20pA-2μA ranges)

Calibration voltage	Resistance <sup>1</sup> standard	Nominal <sup>2</sup> current	Calibration command
Triax cap	100GΩ	0pA	:CAL:PROT:AZERO20P
Triax cap	10GΩ	0pA	:CAL:PROT:AZERO200P
Triax cap	1GΩ	0nA	:CAL:PROT:AZERO2N
Triax cap	100MΩ	0nA	:CAL:PROT:AZERO20N
Triax cap	100MΩ	0nA	:CAL:PROT:AZERO200N
Triax cap	100MΩ	0μA	:CAL:PROT:AZERO2U
1.900000V	100GΩ	19pA	:CAL:PROT:A20PCARD 1.9
-1.900000V	100GΩ	-19pA	:CAL:PROT:AN20PCARD -1.9
1.900000V	10GΩ	190pA	:CAL:PROT:A200PCARD 1.9
-1.900000V	10GΩ	-190pA	:CAL:PROT:AN200PCARD -1.9
1.900000V	1GΩ	1.9nA	:CAL:PROT:A2NCARD 1.9
-1.900000V	1GΩ	-1.9nA	:CAL:PROT:AN2NCARD -1.9
1.900000V	100MΩ	19nA	:CAL:PROT:A20NCARD 1.9
-1.900000V	100MΩ	-19nA	:CAL:PROT:AN20NCARD -1.9
19.00000V	100MΩ	190nA	:CAL:PROT:A200NCARD 19
-19.00000V	100MΩ	-190nA	:CAL:PROT:AN200NCARD -19
190.0000V	100MΩ	1.9μA	:CAL:PROT:A2UCARD 190
-190.0000V	100MΩ	-1.9μA	:CAL:PROT:AN2UCARD -190

<sup>1</sup> Actual resistance standard value determined from calibration data supplied with standard.

<sup>2</sup> Actual calibration current :  $I = V/R$ , where V is the calibration voltage, and R is the actual resistance standard value.  
When using the Model 5156 Electrometer Calibration Standard, the Model 6517A automatically calculates the current from the applied voltage and actual resistance value.

**Table 2-12**  
IEEE-488 bus amps calibration summary (20μA-20mA ranges)

Calibration current	Calibration command
Triax cap	:CAL:PROT:AZERO20U
Triax cap	:CAL:PROT:AZERO200U
Triax cap	:CAL:PROT:AZERO2M
Triax cap	:CAL:PROT:AZERO20M
19.00000μA	:CAL:PROT:A20U 19E-6
19.00000μA	:CAL:PROT:AN20U -19E-6
190.0000μA	:CAL:PROT:A200U 190E-6
190.0000μA	:CAL:PROT:AN200U -190E-6
1.900000mA	:CAL:PROT:A2M 1.9E-3
1.900000mA	:CAL:PROT:AN2M -1.9E-3
19.00000mA	:CAL:PROT:A20M 19E-3
19.00000mA	:CAL:PROT:AN20M -19E-3



**Step 6: Coulombs Calibration**

Perform the steps below to calibrate the coulombs function over the bus. Table 2-13 summarizes the necessary steps.

1. Connect the calibration standard and DC voltage calibrator to the Model 6517A INPUT jack (see Figure 2-5). Initially, make connections to the 1nF capacitor in the standards box.
2. Set the output voltage of the DC calibrator to 0.00000V.
3. Send the following command over the bus:

:CAL:PROT:CZEROA2N

4. Set the calibrator output voltage to +1.900000V, then send the following command over the bus:

:CAL:PROT:C2NCARD 1.9

5. Set the calibrator output voltage to 0.000000V, then send the following command:

:CAL:PROT:CZEROB2N

6. Set the calibrator output voltage to -1.900000V, then send:

:CAL:PROT:CN2NCARD -1.9

7. Repeat steps 3 to 6 for the remaining coulombs calibration steps summarized in Table 2-13.

**Step 7: Temperature Calibration**

Follow the steps below to calibrate the Model 6517A temperature function.

1. Connect the thermocouple calibrator to the Model 6517A EXT TEMP jack (see Figure 2-6).
2. Set the thermocouple calibrator output to 0°C, then send the following command:

:CAL:PROT:TZERO

3. Set the thermocouple calibrator output to 100°C, then send the following command:

:CAL:PROT:T100

**Table 2-13**  
*IEEE-488 bus coulombs calibration summary*

Calibration voltage	Standard <sup>1</sup> capacitance	Nominal <sup>2</sup> charge	Calibration command
0.000000V	1nF	0nC	:CAL:PROT:CZEROA2N
1.900000V	1nF	1.9nC	:CAL:PROT:C2NCARD 1.9
0.000000V	1nF	0nC	:CAL:PROT:CZEROB2N
-1.900000V	1nF	-1.9nC	:CAL:PROT:CN2NCARD -1.9
0.000000V	1nF	0nC	:CAL:PROT:CZEROA20N
19.00000V	1nF	19nC	:CAL:PROT:C20NCARD 19
0.000000V	1nF	0nC	:CAL:PROT:CZEROB20N
-19.00000V	1nF	-19nC	:CAL:PROT:CN20NCARD -19
0.000000V	100nF	0nC	:CAL:PROT:CZEROA200N
1.900000V	100nF	190nC	:CAL:PROT:C200NCARD 1.9
0.000000V	100nF	0nC	:CAL:PROT:CZEROB200N
-1.900000V	100nF	-190nC	:CAL:PROT:CN200NCARD -1.9
0.000000V	100nF	0µC	:CAL:PROT:CZEROA2U
19.00000V	100nF	1.9µC	:CAL:PROT:C2UCARD 19
0.000000V	100nF	0µC	:CAL:PROT:CZEROB2U
-19.00000V	100nF	-1.9µC	100nF :CAL:PROT:CN2UCARD -19

<sup>1</sup>Nominal capacitance standard shown. Refer to calibration data for actual value.

<sup>2</sup>Charge calculated from:  $Q = CV$ , where C is capacitance standard value, and V is the calibrator voltage. When using the Model 5156 Electrometer Calibration Standard, the Model 6517A automatically computes the charge from the applied voltage and the actual capacitance value.

*Step 8: Voltage Source Calibration*

Perform the steps below to calibrate the Model 6517A voltage source. Table 2-14 summarizes these steps.

**WARNING**

**Hazardous voltages will be present when performing the following steps. Avoid touching terminals while performing this procedure.**

1. Select the DCV function and the auto-range mode on the DMM.
2. Temporarily short the ends of the DMM test leads, then enable the DMM REL mode. Leave REL enabled for the remainder of the tests.
3. Connect the DMM to the V SOURCE OUT jacks (see Figure 2-7).
4. Send the following command to the instrument:

```
:CAL:PROT:VSETZ100
```

5. After settling, note the DMM reading, then send the actual DMM reading as a numeric parameter included with the following command:

```
:CAL:PROT:VSRCZ100 <DMM_reading>
```

For example, if the actual DMM reading were 0.005V, you would send the following command:

```
:CAL:PROT:VSRCZ100 5E-3
```

6. Repeat steps 4 and 5 for each voltage source output value listed in Table 2-14. Keep in mind that each calibration point is a two-step process:

- First send the appropriate VSET command to program the voltage source to the correct output value.
- Note the DMM voltage reading, then include that reading as a numeric parameter with the corresponding VSRC command. Be sure to include the minus sign for negative parameters.

**Table 2-14**  
*IEEE-488 bus voltage source calibration summary*

Calibration step	Calibration command*
Output 0V (100V range)	:CAL:PROT:VSETZ100
Program 0V DMM reading	:CAL:PROT:VSRCZ100 <DMM_reading>
Output +40V	:CAL:PROT:VSET40
Program +40V DMM reading	:CAL:PROT:VSRC40 <DMM_reading>
Output +100V	:CAL:PROT:VSET100
Program +100V DMM reading	:CAL:PROT:VSRC100 <DMM_reading>
Output -100V	:CAL:PROT:VSETN100
Program -100V DMM reading	:CAL:PROT:VSRCN100 <DMM_reading>
Output 0V (1000V range)	:CAL:PROT:VSETZ1000
Program 0V DMM reading	:CAL:PROT:VSRCZ1000 <DMM_reading>
Output +400V	:CAL:PROT:VSET400
Program +400V DMM reading	:CAL:PROT:VSRC400 <DMM_reading>
Output +1000V	:CAL:PROT:VSET1000
Program +1000V DMM reading	:CAL:PROT:VSRC1000 <DMM_reading>
Output -1000V	:CAL:PROT:VSETN1000
Program -1000V DMM reading	:CAL:PROT:VSRCN1000 <DMM_reading>

\* <DMM\_reading> parameter is actual DMM reading obtained after programming voltage source output using VSET command from previous step.

### Step 9: Humidity Calibration

Perform the steps below to calibrate the Model 6517A humidity function. These steps are summarized in Table 2-15.

1. Connect the DC voltage calibrator to the rear panel HUMIDITY jack (see Figure 2-8).
2. Set the DC calibrator output to 0.00000V, then send the following command over the bus:

```
:CAL:PROT:HUMZERO
```

3. Repeat steps 2 and 3 for 0.5V and 1V input using the calibrator voltages and commands summarized in Table 2-15.

**Table 2-15**

*IEEE-488 bus humidity calibration summary*

Calibration point	Calibrator voltage	Calibration command
0V (0% RH)	0.00000V	:CAL:PROT:HUMZERO
0.5V (50% RH)	0.50000V	:CAL:PROT:HUM05
1V (100% RH)	1.00000V	:CAL:PROT:HUM1

### Step 10: Program Calibration Dates

To set the calibration date and next due date, use the following commands to do so:

```
:CAL:PROT:DATE <yr>, <mon>, <date> (calibration date)
```

```
:CAL:PROT:NDUE <yr>, <mon>, <date> (next calibration due date)
```

Note that the year, month, and date must be separated by commas. The allowable range for the year is from 1994 to 2093, the month is from 1 to 12, and the date is from 1 to 31.

### Step 11: Save Calibration Constants

Calibration is now complete, so you can store the calibration constants in EEPROM by sending the following command:

```
:CAL:PROT:SAVE
```

#### NOTE

Calibration will be temporary unless you send the SAVE command.

### Step 12: Lock Out Calibration

To lock out further calibration, send the following command after completing the calibration procedure:

```
:CAL:PROT:LOCK
```

## 2.10 Single-point calibration

Normally, the complete comprehensive calibration procedure should be performed to ensure that the entire instrument is properly calibrated. In some instances, however, it may be desirable to calibrate only certain ranges or functions. For those cases, a single-point calibration feature is included in the Model 6517A.

The following paragraphs give an overview of performing single-point calibration, both from the front panel and over the IEEE-488 bus. For details on specific procedures and test equipment connections, refer to paragraphs 2.8 and 2.9 of this section. For comprehensive information on IEEE-488 bus calibration commands, see Section 3.

Remember that calibration must first be unlocked. To unlock comprehensive calibration, press in on the CAL switch.

### 2.10.1 Front panel single-point calibration

Front panel single-point calibration can be performed by using the POINT-CALS selection in the CALIBRATION menu. You will then be prompted as to which function to calibrate using the following menu:

```
VOLTS  AMPS  CHARGE  V-SOURCE ►
◀ EXT-TEMP  HUMIDITY  ZEROCHECK
```

If you choose VOLTS, AMPS, or CHARGE, you can then choose whether to calibrate all ranges for that function, or just a single range. For example, the menu selections for the volts function include:

```
CHOOSE VOLTS RANGE
ALL  2V  20V  200V
```

With the ALL selection, all steps for that function will be carried out without duplicating the zero calibration step for that range. See paragraph 2.8 for details on front panel comprehensive calibration steps.

Once you have calibrated all desired functions and ranges, exit the calibration menu by pressing the EXIT key. You will then be prompted as to whether or not the new calibration points are to be saved. To make changes permanent, save calibration; however, choose not to save calibration if you wish calibration to be only temporary.

#### Example

Assume that you wish to calibrate the volts function. Follow the steps below to do so:

1. Turn on the Model 6517A, and allow the instrument to warm up for at least one hour before performing calibration.
2. Press in on the front panel CAL switch to unlock calibration.
3. Press the MENU key. The instrument will display the following menu:

```
MAIN MENU
SAVESETUP COMMUNICATION CAL
```

4. Select CAL, then press ENTER. If the optional Model 5156 Calibration Standard is connected to the DIGITAL I/O port, the following prompt will be displayed:

```
USE CAL OPTION CARD?
YES NO
```

5. Select yes, then press ENTER.
6. The following menu will be displayed:

```
PERFORM CALIBRATION
COMPREHENSIVE POINT-CALS
```

7. Select POINT-CALS, then press ENTER. The Model 6517A will prompt you to select the function:

```
POINT-CALS
VOLTS AMPS CHARGE VSOURCE ►
◀ EXT-TEMP HUMIDITY ZEROCHECK
```

8. Select VOLTS, then press ENTER. The unit will prompt you to choose the range:

```
CHOOSE VOLTS RANGE
ALL 2V 20V 200V
```

9. Select the desired option, then press ENTER. If you wish to calibrate all volts ranges, choose ALL; otherwise, select the range to be calibrated, then press the ENTER key.
10. Follow the prompts regarding the various calibration steps, and refer to paragraph 2.8 for additional information.
11. Repeat the above steps for other calibration points, if desired.
12. If desired, select CAL-DATES in the calibration menu, then set the calibration date and due date accordingly.
13. Press EXIT as necessary to return to normal display. If you wish calibration to be permanent, select the save option; valid calibration constants will be saved, and calibration will be locked out.

### 2.10.2 IEEE-488 bus single-point calibration

To perform IEEE-488 bus single-point calibration, simply connect the appropriate signal, then send the corresponding

calibration commands. Keep in mind that all commands for a given range or function must be sent in order to completely calibrate that range or function. (See paragraph 2.9 for more information on commands and procedures.)

Remember that you must unlock calibration first. Also, it is strongly recommended that you perform voltage offset, bias current, and zero check calibration before calibrating a volts, amps, or coulombs range or function.

Before sending any calibration commands, you must send the “:CAL:PROT:INIT” command to initialize calibration. After calibrating the desired point(s), you must then save the new calibration constants by sending the “:CAL:PROT:SAVE” command over the bus. You can then lock out calibration by sending “:CAL:PROT:LOCK”.

#### Example

As an example, assume that you intend to calibrate the 20V range of the volts function. The basic steps are summarized below:

1. Turn on the Model 6517A power and allow the instrument to warm up for at least one hour before performing calibration.
2. Press the front panel CAL switch to unlock calibration.
3. Send the following command over the bus to initiate calibration:  
:CAL:PROT:INIT
4. Perform voltage offset, bias current, and zero check calibration as outlined in Step 2 of the IEEE-488 bus calibration procedure in paragraph 2.9.2.
5. Connect the DC voltage calibrator to the INPUT jack (see Figure 2-2).
6. Set the output voltage of the DC calibrator to 0.000000V, then send the following command:  
:CAL:PROT:VZERO20
7. Set the output voltage of the DC calibrator to +19.000000V, then send the following command:  
:CAL:PROT:V20 19
8. Set the output voltage of the DC calibrator to -19.000000V, then send the following command:  
:CAL:PROT:VN20 -19
9. Repeat steps 6 through 8 as desired for other calibration points.
10. If desired, send the following commands to program the calibration date and calibration due date:  
:CAL:PROT:DATE <yr>,<mon>,<date>  
:CAL:PROT:NDUE <yr>,<mon>,<date>

Here, <yr> is the year (1994-2093), <mon> is the month (1-12), and <date> can have any value between 1 and 31.

11. Send the following command to save calibration constants:

```
:CAL:PROT:SAVE
```

12. Finally, send the following command to lock out calibration:

```
:CAL:PROT:LOCK
```

## 2.11 Programming calibration dates

Normally calibration dates are programmed when the instrument is calibrated. However, you can change these dates at any time by using the basic procedure outlined below.

1. From normal display, press the MENU key, and note that the instrument displays the following:

```
MAIN MENU
SAVESETUP COMMUNICATION CAL
```

2. Select CAL, then press ENTER. The following options will be displayed:

```
PERFORM CALIBRATION
COMPREHENSIVE POINT-CALS ►
◀ CAL-DATES OFFSET-ADJ CAL-OPT
```

3. Select CAL-DATES, and note that unit displays the following selections:

```
CALIBRATION DATES
VIEW DISPLAY-AT-POWERUP CHANGE
```

4. Choose the option based on the desired action:

**VIEW:** Allows you to view the last calibration and calibration due dates.

**DISPLAY-AT-POWERUP:** Allows you to select whether or not calibration dates are automatically displayed at power-up (choose YES to enable, NO to disable calibration date display at power-up).

**CHANGE:** Use this option to change the last calibration date or the calibration due date. Simply follow the display prompts to change the dates as desired.

# 3

## Calibration Command Reference

---

### 3.1 Introduction

This section contains detailed information on the various Model 6517A IEEE-488 bus calibration commands. Section 2 of this manual covers detailed calibration procedures. For information on additional commands to control other instrument functions, refer to the Model 6517A User Manual.

Information in this section includes:

- 3.2 Command summary:** Summarizes all commands necessary to perform comprehensive calibration.
- 3.3 Miscellaneous commands:** Covers commands that initiate calibration, program calibration dates, lock out calibration, and save calibration constants.
- 3.4 Meter commands:** Details those commands used to calibrate the Model 6517A meter functions (volts, amps, and coulombs).
- 3.5 Voltage source calibration commands:** Outlines those commands used to calibrate the Model 6517A voltage source.

**3.6 Temperature calibration commands:** Discusses commands required to calibrate the temperature function.

**3.7 Humidity calibration commands:** Covers commands used for calibrating the humidity function.

**3.8 Calibration errors:** Summarizes bus calibration error commands, and discusses how to obtain error information.

**3.9 Detecting calibration step completion:** Covers how to determine when each calibration step is completed by using the \*OPC and \*OPC? commands.

### 3.2 Command summary

Table 3-1 summarizes Model 6517A calibration commands.

**Table 3-1**  
IEEE-488 bus calibration command summary

Command	Description
CALibration:	Calibration subsystem
PROTeCted:	Commands protected by CAL switch
INITiate	Required before performing ANY cal steps
VZERO2	2V range zero step
V2 <Nrf>	+2V step
VN2 <Nrf>	-2V step
VZERO20	20V range zero step
V20 <Nrf>	+20V step
VN20 <Nrf>	-20V step
VZERO200	200V range zero step
V200 <Nrf>	+200V step
VN200 <Nrf>	-200V step
AZERO20P	20pA range zero step
A20P <Nrf>	+20pA step
A20PCARD <Nrf>	+20pA step (using cal standard)
AN20P <Nrf>	-20pA step
AN20PCARD <Nrf>	-20pA step (using cal standard)
AZERO200P	200pA range zero step
A200P <Nrf>	+200pA step
A200PCARD <Nrf>	+200pA step (using cal standard)
AN200P <Nrf>	-200pA step
AN200PCARD <Nrf>	-200pA step (using cal standard)
AZERO2N	2nA range zero step
A2N <Nrf>	+2nA step
A2NCARD <Nrf>	+2nA step (using cal standard)
AN2N <Nrf>	-2nA step
AN2NCARD <Nrf>	-2nA step (using cal standard)
AZERO20N	20nA range zero step
A20N <Nrf>	+20nA step
A20NCARD <Nrf>	+20nA step (using cal standard)
AN20N <Nrf>	-20nA step
AN20NCARD <Nrf>	-20nA step (using cal standard)
AZERO200N	200nA range zero step
A200N <Nrf>	+200nA step
A200NCARD <Nrf>	+200nA step (using cal standard)
AN200N <Nrf>	-200nA step
AN200NCARD <Nrf>	-200nA step (using cal standard)
AZERO2U	2μA range zero step
A2U <Nrf>	+2μA step
A2UCARD <Nrf>	+2μA step (using cal standard)
AN2U <Nrf>	-2μA step
AN2UCARD <Nrf>	-2μA step (using cal standard)
AZERO20U	20μA range zero step
A20U <Nrf>	+20μA step
AN20U <Nrf>	-20μA step
AZERO200U	200μA range zero step
A200U <Nrf>	+200μA step
AN200U <Nrf>	-200μA step

**Table 3-1**  
IEEE-488 bus calibration command summary (cont.)

Command	Description
CALibration:	
PROTeCted:	
AZERO2M	2mA range zero step
A2M <Nrf>	+2mA step
AN2M <Nrf>	-2mA step
AZERO20M	2mA range zero step
A20M <Nrf>	+20mA step
AN20M <Nrf>	-20mA step
CZEROA2N	2nC range zero check part A
C2N <Nrf>	+2nC step
C2NCARD <Nrf>	+2nC step (using cal standard)
CZEROB2N	2nC range zero check part B
CN2N <Nrf>	-2nC step
CN2NCARD <Nrf>	-2nC step (using cal standard)
CZEROA20N	20nC range zero check part A
C20N <Nrf>	+20nC step
C20NCARD <Nrf>	+20nC step (using cal standard)
CZEROB20N	20nC range zero check part B
CN20N <Nrf>	-20nC step
CN20NCARD <Nrf>	-20nC step (using cal standard)
CZEROA200N	200nC range zero check part A
C200N <Nrf>	+200nC step
C200NCARD <Nrf>	+200nC step (using cal standard)
CZEROB200N	200nC range zero check part B
CN200N <Nrf>	-200nC step
CN200NCARD <Nrf>	-200nC step (using cal standard)
CZEROA2U	2 $\mu$ C range zero check part A
C2U <Nrf>	+2 $\mu$ C step
C2UCARD <Nrf>	+2 $\mu$ C step (using cal standard)
CZEROB2U	2 $\mu$ C range zero check part B
CN2U <Nrf>	-2 $\mu$ C step
CN2UCARD <Nrf>	-2 $\mu$ C step (using cal standard)
TZERO	0mV (0°C) temperature step
T100	+4.095mV (100°C) temperature step
VSETZ100	Set voltage source to 0V for next command
VSR CZ100 <Nrf>	Voltage source 100V range 0V cal
VSETZ1000	Set voltage source to 0V for next command
VSR CZ1000 <Nrf>	Voltage source 1000V range 0V cal
VSET40	Set voltage source to +40V
VSR C40 <Nrf>	Voltage source +40 V cal
VSET100	Set voltage source to +100V
VSR C100 <Nrf>	Voltage source +100V cal
VSETN100	Set voltage source to -100V
VSR CN100 <Nrf>	Voltage source -100V cal
VSET400	Set voltage source to +400V
VSR C400 <Nrf>	Voltage source +400V cal



**Table 3-1**  
IEEE-488 bus calibration command summary (cont.)

Command	Description
CALibration: PROTected: VSET1000 VSRC1000 <Nrf> VSETN1000 VSRCN1000 <Nrf> HUMZERO HUM05 HUM1 LOCK  SAVE DATE <yyyy, mm, dd>  DATE? NDUE <yyyy, mm, dd> NDUE? SWITCh? CALTEMP  CALibration: UNPRotected: VOFFset IOFFset EERR? VERR? AERR? CERR? TERR? FERR? OPTion?	Set voltage source to +1000V Voltage source +1000 V cal Set voltage source to -1000 V Voltage source -1000 V cal Humidity input 0 V step Humidity input 0.5 V step Humidity input 1.0 V step Re-locks the calibration paths. (A new CAL switch press and CAL:PROT:INIT command are required before any cal commands can be performed again.) Saves the cal constants in NVRAM Calibration date yyyy = year (1994-2093), mm = month (1-12), dd =date (1-31) Request calibration date Calibration due date Request calibration due date Request CAL switch state (0 = unlocked, 1 = locked) Acquire the calibration temperature.  These commands not protected by CAL switch Perform offset voltage calibration Perform bias current calibration Request cal execution error status Request voltage function cal errors Request amps function cal errors Request coulombs function cal errors Request temperature function cal errors Request factory calibration errors Request option presence status

NOTE: Upper-case letters indicate short form of each command. For example, instead of sending “:CALibration:PROTected:INITiate”, you can send “:CAL:PROT:INIT”.

### 3.3 Miscellaneous commands

Miscellaneous commands are those commands that have such functions as initiating calibration, saving calibration constants, locking out calibration, and programming date parameters.

#### 3.3.1 :INIT (CALibration:PROTected:INITiate)

<b>Purpose</b>	To initiate calibration.	
<b>Format</b>	:cal:prot:init	
<b>Parameter</b>	None	
<b>Description</b>	The :INIT command enables Model 6517A calibration when performing these procedures over the bus. In general, this command must be sent to the unit before sending any other comprehensive calibration command.	
<b>Programming Note</b>	The :INIT command should be sent only once before performing either complete or single-point calibration. Do not send :INIT before each calibration step.	
<b>Example</b>	:CAL:PROT:INIT	Initiate calibration

#### 3.3.2 :LOCK (CALibration:PROTected:LOCK)

<b>Purpose</b>	To lock out calibration.	
<b>Format</b>	:cal:prot:lock	
<b>Parameter</b>	None	
<b>Description</b>	The :LOCK command allows you to lock out comprehensive calibration after completing those procedures. Thus, :LOCK performs the opposite of pressing in on the front panel CAL switch.	
<b>Programming Note</b>	To unlock comprehensive calibration, press in on the CAL switch with the power turned on.	
<b>Example</b>	:CAL:PROT:LOCK	Lock out calibration

### 3.3.3 :SWITCh? (:CALibration:PROTected:SWITCh?)

**Purpose** To read calibration lock status.

**Format** :cal:prot:swit?

**Response**  
0 Calibration locked  
1 Calibration unlocked.

**Description** The :SWITCh? query requests status from the Model 6517A on calibration locked/unlocked state. Calibration must be unlocked by pressing in on the CAL switch while power is turned on before calibration can be performed.

**Example** :CAL:PROT:SWIT? Request CAL switch status.

### 3.3.4 :SAVE (:CALibration:PROTected:SAVE)

**Purpose** To save calibration constants in EEPROM after the calibration procedure.

**Format** :cal:prot:save

**Parameter** None

**Description** The :SAVE command stores internally calculated calibration constants derived during comprehensive calibration in EEPROM. EEPROM is non-volatile memory, and calibration constants will be retained indefinitely once saved. Generally, :SAVE is sent after all other calibration steps (except for :LOCK).

**Programming Note** Calibration will be only temporary unless the :SAVE command is sent to permanently store calibration constants.

**Example** :CAL:PROT:SAVE Save calibration constants

**3.3.5 :DATE** (:CALibration:PROTected:DATE)

<b>Purpose</b>	To send the calibration date to the instrument.	
<b>Format</b>	:cal:prot:date <yr>, <mon>, <day>	
<b>Parameters</b>	<yr> = year (yyyy, 1994 to 2093) <mon> = month (mm, 1 to 12) <day> = day of month (dd, 1 to 31)	
<b>Query Format</b>	:cal:prot:date?	
<b>Response</b>	<yr> , <mon> , <day>	
<b>Description</b>	The :DATE command allows you to store the calibration date in instrument memory for future reference. You can read back the date from the instrument over the bus by using the :DATE? query, or by using the CAL-DATES selection in the front panel CAL menu.	
<b>Programming Note</b>	The year, month, and day parameters must be delimited by commas.	
<b>Examples</b>	:CAL:PROT:DATE 1998,9,21	Send cal date (9/21/98).
	:CAL:PROT:DATE?	Request date.

**3.3.6 :NDUE** (:CALibration:PROTected:NDUE)

<b>Purpose</b>	To send the next calibration due date to the instrument.	
<b>Format</b>	:cal:prot:ndue <yr>, <mon>, <day>	
<b>Parameters</b>	<yr> = year (yyyy, 1994 to 2093) <mon> = month (mm, 1 to 12) <day> = day of month (dd, 1 to 31)	
<b>Query Format</b>	:cal:prot:ndue?	
<b>Response</b>	<yr>, <mon>, <day>	
<b>Description</b>	The :NDUE command allows you to store the date when calibration is next due in instrument memory. You can read back the next due date from the instrument over the bus by using the :NDUE? query, or by using the CAL-DATES selection in the front panel CAL menu.	
<b>Programming Note</b>	The next due date parameters must be delimited by commas.	
<b>Examples</b>	:CAL:PROT:NDUE 1998,9,21	Send due date (9/21/98).
	:CAL:PROT:NDUE?	Request due date.

### 3.3.7 :DATA? (:CALibration:PROTeCted:DATA?)

**Purpose** To download calibration constants from the Model 6517A.

**Format** :cal:prot:data?

**Response** <Cal\_1>,<Cal\_2>,...<Cal\_n>

**Description** The :DATA? query allows you to request calibration constants stored in EEROM from the instrument. This command can be used to compare present constants with those from a previous calibration procedure to verify that calibration was performed properly. The returned values are floating-point ASCII numbers delimited by commas (,).

**Programming Note** See Appendix B for summary of constants returned by the :DATA? query.

**Example** :CAL:PROT:DATA? Request calibration constants.

### 3.3.8 :OPT? (:CALibration:UNPRotected:OPTion?)

**Purpose** To detect the presence of the optional calibration standard.

**Format** :cal:prot:opt?

**Response** 0 Cal standard not present  
5156-CALOPT Cal standard present

**Description** The :OPT? query allows you to determine whether or not the optional Model 5156 Electrometer Calibration Standard is connected to the Model 6517A DIGITAL I/O port. The unit will respond with the appropriate string depending on whether or not the calibration standard is connected and operational.

**Example** :CAL:PROT:OPT? Request option presence status.

### 3.3.9 :CALTEMP (:CALibration:PROTeCted:CALTEMP)

**Purpose** To acquire the calibration temperature.

**Format** :cal:prot:caltemp

**Response** None

**Description** The :CALTEMP command acquires the temperature at which the Model 6517A was calibrated. The command should be sent without the thermocouple connected to the Model 6517A and may be issued at any point during calibration. When calibrating from the front panel, the calibration temperature will be acquired when the calibration dates and constants are saved. (This command is supported with main firmware revision level B07 or later.)

**Example** :CAL:PROT:CALTEMP Acquire calibration temperature.

## 3.4 Meter commands

Meter commands include those necessary to null offsets and calibrate the volts, amps, and coulombs measurement functions.

### 3.4.1 Offset commands

	<b>:VOFF</b> (:CALibration:UNPRotected:VOFFset)
<b>Purpose</b>	To null voltage offsets.
<b>Format</b>	:cal:unpr:voff
<b>Parameter</b>	None
<b>Description</b>	The :VOFF command performs voltage offset calibration and is normally used as part of the calibration procedure. :VOFF can also be sent during normal operation to null voltage offsets at any time.
<b>Programming Note</b>	<ol style="list-style-type: none"> <li>1. :VOFF is not protected by the CAL switch.</li> <li>2. When :VOFF is used as part of the normal calibration procedure, voltage offset compensation constants are permanently saved. When :VOFF is sent during normal operation (with calibration locked), voltage offset compensation is only temporary.</li> </ol>
<b>Example</b>	:CAL:PROT:VOFF      Perform voltage offset calibration
	<b>:IOFF</b> (:CALibration:UNPRotected:IOFFset)
<b>Purpose</b>	To null bias current.
<b>Format</b>	:cal:unpr:ioff
<b>Parameter</b>	None
<b>Description</b>	The :IOFF command performs bias current calibration and is normally used as part of the calibration procedure. :IOFF can also be sent during normal operation to null bias current at any time.
<b>Programming Note</b>	<ol style="list-style-type: none"> <li>1. :IOFF is not protected by the CAL switch.</li> <li>2. When :IOFF is used as part of the normal calibration procedure, bias current compensation constants are permanently saved. When :IOFF is sent during normal operation (with calibration locked), bias current compensation is only temporary.</li> </ol>
<b>Example</b>	:CAL:PROT:IOFF      Perform bias current calibration

### 3.4.2 Volts function calibration commands

**Purpose** To calibrate voltage function ranges.

**Format** See Table 3-2.

**Parameter** See Table 3-2.

**Table 3-2**

*Volts function calibration commands and parameters*

Range	Command format*	<Cal_voltage> parameter limits (V)
2V	:cal:prot:vzero2 :cal:prot:v2 <Cal_voltage> :cal:prot:vn2 <Cal_voltage>	None 0.95 to 2.05 -0.95 to -2.05
20V	:cal:prot:vzero20 :cal:prot:v20 <Cal_voltage> :cal:prot:vn20 <Cal_voltage>	None 9.5 to 20.5 -9.5 to -20.5
200V	:cal:prot:vzero200 :cal:prot:v200 <Cal_voltage> :cal:prot:vn200 <Cal_voltage>	None 95 to 205 -95 to -205

\* Command short form shown.

**Description**

The :V commands calibrate the three volts function ranges: 2V, 20V, and 200V. Each range requires three commands, corresponding to zero, positive full range, and negative full range. For example, :VZERO2 calibrates 2V range zero, while :V2 and :VN2 calibrate positive 2V full range and negative 2V full-range values respectively. Normally, 95% of full-range values should be used. For example, +19V and -19V should be used to calibrate the 20V range.

**Programming Note**

All three commands for a given range must be sent in order to properly calibrate that range.

**Examples**

:CAL:PROT:VZERO20	Cal 20V range zero.
:CAL:PROT:V20 19	Cal 20V positive 95% of full range.
:CAL:PROT:VN20 -19	Cal 20V negative 95% of full range.

### 3.4.3 Amps calibration commands

<b>Purpose</b>	To calibrate amps function ranges.
<b>Format</b>	See Tables 3-3 and 3-4.
<b>Parameter</b>	See Tables 3-3 and 3-4.

**Table 3-3**

*Amps function calibration commands and parameters (all ranges, without calibration standard)*

Range	Command format*	<Cal_current> parameter limits (A)
20pA	:cal:prot:azero20p :cal:prot:a20p <Cal_current> :cal:prot:an20p <Cal_current>	None 9.5E-12 to 20.5E-12 -9.5E-12 to -20.5E-12
200pA	:cal:prot:azero200p :cal:prot:a200p <Cal_current> :cal:prot:an200p <Cal_current>	None 95E-12 to 205E-12 -95E-12 to -205E-12
2nA	:cal:prot:azero2n :cal:prot:a2n <Cal_current> :cal:prot:an2n <Cal_current>	None 0.95E-9 to 2.05E-9 -0.95E-9 to -2.05E-9
20nA	:cal:prot:azero20n :cal:prot:a20n <Cal_current> :cal:prot:an20n <Cal_current>	None 9.5E-9 to 20.5E-9 -9.5E-9 to -20.5E-9
200nA	:cal:prot:azero200n :cal:prot:a200n <Cal_current> :cal:prot:an200n <Cal_current>	None 95E-9 to 205E-9 -95E-9 to -205E-9
2μA	:cal:prot:azero2u :cal:prot:a2u <Cal_current> :cal:prot:an2u <Cal_current>	None 0.95E-6 to 2.05E-6 -0.95E-6 to -2.05E-6
20μA	:cal:prot:azero20u :cal:prot:a20u <Cal_current> :cal:prot:an20u <Cal_current>	None 9.5E-6 to 20.5E-6 -9.5E-6 to -20.5E-6
200μA	:cal:prot:azero200u :cal:prot:a200u <Cal_current> :cal:prot:an200u <Cal_current>	None 95E-6 to 205E-6 -95E-6 to -205E-6
2mA	:cal:prot:azero2m :cal:prot:a2m <Cal_current> :cal:prot:an2m <Cal_current>	None 0.95E-3 to 2.05E-3 -0.95E-3 to -2.05E-3
20mA	:cal:prot:azero20m :cal:prot:a20m <Cal_current> :cal:prot:an20m <Cal_current>	None 9.5E-3 to 20.5E-3 -9.5E-3 to -20.5E-3

\* Command short form shown.



**Table 3-4**

*Amps function calibration commands and parameters (20pA-2μA ranges, using calibration standard)*

Range	Command format*	<Cal_voltage> parameter limits (V)
20pA	:cal:prot:azero20p :cal:prot:a20pcard <Cal_voltage> :cal:prot:an20pcard <Cal_voltage>	None 0.95 to 2.05 -0.95 to -2.05
200pA	:cal:prot:azero200p :cal:prot:a200pcard <Cal_voltage> :cal:prot:an200pcard <Cal_voltage>	None 0.95 to 2.05 -0.95 to -2.05
2nA	:cal:prot:azero2n :cal:prot:a2ncard <Cal_voltage> :cal:prot:an2ncard <Cal_voltage>	None 0.95 to 2.05 -0.95 to -2.05
20nA	:cal:prot:azero20n :cal:prot:a20ncard <Cal_voltage> :cal:prot:an20ncard <Cal_voltage>	None 0.95 to 2.05 -0.95 to -2.05
200nA	:cal:prot:azero200n :cal:prot:a200ncard <Cal_voltage> :cal:prot:an200ncard <Cal_voltage>	None 9.5 to 2.05 -9.5 to -2.05
2μA	:cal:prot:azero2u :cal:prot:a2ucard <Cal_voltage> :cal:prot:an2ucard <Cal_voltage>	None 95 to 205 -95 to -205

\* Command short form shown.

NOTE: Model 5156 Electrometer Calibration Standard and DC voltage calibrator are required to use these commands.

**Description**

The :A commands calibrate the amps function ranges using a suitable current source. Each range requires three commands, corresponding to zero, positive full range, and negative full range. For example, :AZERO2N calibrates 20nA range zero, while :A20N and :AN20N calibrate positive 20nA full range and negative 20nA full range values respectively. Commands using a current source to calibrate all ranges are summarized in Table 3-3. Normally 95% of full-range values should be used. For example, +19mA and -19mA should be used to calibrate the 20mA range.

The :A<range>CARD commands calibrate the 20pA to 2μA ranges using the optional Model 5156 Electrometer Calibration Standard and a DC voltage calibrator. Commands for use with the calibration unit and DC voltage calibrator are listed in Table 3-4.

**Programming Note**

All three commands for a given range must be used in order properly calibrate that range.

**Examples**

:CAL:PROT:AZERO20P	Cal 20pA range zero
:CAL:PROT:A20P 19E-12	Cal 20pA positive 95% of full range
:CAL:PROT:AN20P -19E-12	Cal 20pA negative 95% of full range
:CAL:PROT:A20PCARD 1.9	Cal 20pA range with cal standard
:CAL:PROT:AN20PCARD -1.9	Cal 20pA range with cal standard

### 3.4.4 Coulombs calibration commands

**Purpose** To calibrate coulombs function ranges.

**Format** See Tables 3-5 and 3-6.

**Parameter** See Tables 3-5 and 3-6.

**Table 3-5**

*Coulombs function calibration commands and parameters (without calibration standard)*

Range	Command format*	<Cal_charge> parameter limits (Q)
2nC	:cal:prot:czeroa2n :cal:prot:c2n <Cal_charge> :cal:prot:czerob2n :cal:prot:cn2n <Cal_charge>	None 0.95E-9 to 2.05E-9 None -0.95E-9 to -2.05E-9
20nC	:cal:prot:czeroa20n :cal:prot:c20n <Cal_charge > :cal:prot:czerob20n :cal:prot:cn20n <Cal_charge>	None 9.5E-9 to 20.5E-9 None -9.5E-9 to -20.5E-9
200nC	:cal:prot:czeroa200n :cal:prot:c200n <Cal_charge> :cal:prot:czerob200n :cal:prot:cn200n <Cal_charge>	None 95E-9 to 205E-9 None -95E-9 to -205E-9
2µC	:cal:prot:czeroa2u :cal:prot:c2u <Cal_charge> :cal:prot:czerob2u :cal:prot:cn2u <Cal_charge>	None 0.95E-6 to 2.05E-6 None -0.95E-6 to -2.05E-6

\*Command short form shown.

**Table 3-6**

*Coulombs function calibration commands and parameters (using calibration standard)*

Range	Command format*	<Cal_voltage> parameter limits (V)
2nC	:cal:prot:czeroa2n :cal:prot:c2ncard <Cal_voltage> :cal:prot:czerob2n :cal:prot:cn2ncard <Cal_voltage>	None 0.95 to 2.05 None -0.95 to -2.05
20nC	:cal:prot:czeroa20n :cal:prot:c20ncard <Cal_voltage> :cal:prot:czerob20n :cal:prot:cn20ncard <Cal_voltage>	None 9.5 to 20.5 None -9.5 to -20.5
200nC	:cal:prot:czeroa200n :cal:prot:c200ncard <Cal_voltage> :cal:prot:czerob200n :cal:prot:cn200ncard <Cal_voltage>	None 95 to 205 None -95 to -205
2 $\mu$ C	:cal:prot:czeroa2u :cal:prot:c2ucard <Cal_voltage> :cal:prot:czerob2u :cal:prot:cn2ucard <Cal_voltage>	None 9.5 to 20.5 None -9.5 to -20.5

\* Command short form shown.

NOTE: Model 5156 Electrometer Calibration Standard and DC voltage calibrator are required to use these commands.

**Description**

The :C commands calibrate the coulombs function ranges using a suitable charge source. Each range requires four commands, corresponding to zero A, positive full range, zero B, and negative full range. For example, :CZEROA2N and :CZEROB2N calibrate 20nC range zeroes, while :C20N and :CN20N calibrate positive 20nC full range and negative 20nC full-range values respectively. Normally, 95% of full-range values are used (for example, 19nC). Commands using a charge source to calibrate all ranges are summarized in Table 3-5.

The :C<range>CARD commands calibrate the coulombs ranges using the optional Model 5156 Electrometer Calibration Standard and a DC voltage calibrator. Commands for use with the calibration standard and DC voltage calibrator are listed in Table 3-6.

**Programming Notes**

1. All four commands for a given range must be used in order to properly calibrate that range.
2. Appropriate zero command must be sent before full-scale command. (A command before positive full-scale command; B command before negative full-scale command.)

**Examples**

:CAL:PROT:CZEROA200N	Cal 200nA range zero A.
:CAL:PROT:C200N 190E-9	Cal 200nA positive 95% of full range.
:CAL:PROT:CZEROB200N	Cal 200nA range zero B.
:CAL:PROT:CN200N -190E-9	Cal 200nA negative 95% of full range.
:CAL:PROT:C200NCARD 190	Cal 200nA range with cal standard.
:CAL:PROT:CN200NCARD -190	Cal 200nA range with cal standard.

### 3.5 Voltage source calibration commands

**Purpose** To calibrate the Model 6517A voltage source.

**Format** See Table 3-7.

**Parameter** See Table 3-7.

**Description** The :V commands calibrate the Model 6517A voltage source. Each calibration point uses two commands. First, the :VSET command is used to program the voltage source for a specific output voltage. An accurate voltmeter is then used to measure the actual output voltage, and that value is then sent back to the Model 6517A with the :VRC command to compensate for any discrepancies between the programmed source value and actual output voltage.

- Programming Notes**
1. All commands for a given range (100V or 1000V) should be sent to properly calibrate that range.
  2. The appropriate VSET must be sent before the corresponding VSRC command.

**Examples**

:cal:prot:vset100	Set output to 100V.
:cal:prot:vsrc 100.5	Program DMM reading.

**Table 3-7**  
Voltage source calibration commands

Command format*	<DMM Reading> parameter range
:cal:prot:vsetz100	None
:cal:prot:vsrcz100 <DMM_reading>	-1V to +1V
:cal:prot:vsetz1000	None
:cal:prot:vsrcz1000 <DMM_reading>	-1V to +1V
:cal:prot:vset40	None
:cal:prot:vsrc40 <DMM_reading>	35V to 45V
:cal:prot:vset100	None
:cal:prot:vsrc100 <DMM_reading>	95V to 105V
:cal:prot:vsetn100	None
:cal:prot:vsrcn100 <DMM_reading>	-95V to -105V
:cal:prot:vset400	None
:cal:prot:vsrc400 <DMM_reading>	395V to 405V
:cal:prot:vset1000	None
:cal:prot:vsrc1000 <DMM_reading>	995V to 1005V
:cal:prot:vsetn1000	None
:cal:prot:vsrcn1000 <DMM_reading>	-995V to -1005V

\*Command short form shown.

### 3.6 Temperature calibration commands

<b>Purpose</b>	To calibrate the temperature function.	
<b>Format</b>	:cal:prot:tzero	0mV (0°C) cal point
	:cal:prot:t100	4.095mV (100°C) cal point
<b>Parameter</b>	None	
<b>Description</b>	The :T commands calibrate the Model 6517A temperature function. The only two temperature calibration points correspond to 0mV input and 4.095mV input respectively. A suitable reference junction compensated type K thermocouple calibrator is required for calibration.	
<b>Example</b>	:CAL:PROT:TZERO	Cal 0mV temperature point.

### 3.7 Humidity calibration commands

<b>Purpose</b>	To calibrate the humidity function.	
<b>Format</b>	:cal:prot:humzero	0V cal point
	:cal:prot:hum05	0.5V cal point
	:cal:prot:hum1	1V cal point
<b>Parameter</b>	None	
<b>Description</b>	The :HUM commands calibrate the Model 6517A humidity function. Three calibration points are required: 0V, 0.5V, and 1V, which correspond to 0%, 50%, and 100% relative humidity respectively.	
<b>Example</b>	:CAL:PROT:HUM05	Cal 50% humidity point.

## 3.8 Calibration errors

### 3.8.1 Error query commands

<b>Purpose</b>	To request calibration errors over the bus.	
<b>Format</b>	<pre> :cal:prot:eerr? :cal:prot:verr? :cal:prot:aerr? :cal:prot:cerr? :cal:prot:terr? :cal:prot:herr? :cal:prot:serr? :cal:prot:ferr? </pre>	<pre> Request cal execution error status Request voltage function cal errors Request current function cal errors Request charge function cal errors Request temperature function cal errors Request humidity function cal errors Request voltage source cal errors Request factory cal errors </pre>
<b>Parameter</b>	None	
<b>Description</b>	The calibration error queries allow you to access the various calibration error messages that might be generated during calibration. A separate query is provided for each function or category. For example, the :cal:prot:verr? query is used to request only those errors that occur while calibrating the voltage function.	
<b>Programming Note</b>	See Appendix B for a complete listing of calibration error messages.	
<b>Examples</b>	<pre> :CAL:PROT:AERR? :CAL:PROT:SERR? </pre>	<pre> Request amps cal errors. Request voltage source cal errors. </pre>

### 3.8.2 Detecting calibration errors

If an error occurs during any calibration step, the Model 6517A will generate one of the error messages summarized above. Several methods to detect calibration errors are discussed below.

#### Error queue

As with other Model 6517A errors, any calibration errors will be reported in the bus error queue. You can read this queue by using the appropriate error query (see paragraph 3.8.1). The Model 6517A will respond with the appropriate error message, as summarized in Appendix B.

#### Status byte EAV (Error Available) bit

Whenever an error is available in the error queue, the EAV (Error Available) bit (bit 2) of the status byte will be set. Use the `*STB?` query or serial polling to obtain the status byte, then test bit 2 to see if it is set. If the EAV bit is set, an error has occurred, and you can use the appropriate error query to read the error and at the same time clear the EAV bit in the status byte. Use `:SYST;ERR?` for appropriate detailed error queue message.

#### Generating an SRQ on error

To program the instrument to generate an SRQ when an error occurs, send the following command: `*SRE 4`. This command will enable SRQ when the EAV bit is set. You can then read the status byte and error queue as outlined above to check for errors and to determine the exact nature of the error.

## 3.9 Detecting calibration step completion

When sending calibration commands over the IEEE-488 bus, you must wait until the instrument completes the current operation before sending a command. You can use either `*OPC?` or `*OPC` to help determine when each calibration step is completed.

### 3.9.1 Using the `*OPC?` query

With the `*OPC?` (operation complete) query, the instrument will place an ASCII 1 in the output queue when it has completed each step. To determine when the OPC response is ready, do the following:

1. Repeatedly test the MAV (Message Available) bit (bit 4) in the status byte and wait until it is set. (You can request the status byte by using the `*STB?` query or serial polling.)

2. When MAV is set, a message is available in the output queue, and you can read the output queue and test for an ASCII 1.
3. After reading the output queue, repeatedly test MAV again until it clears. At this point, the calibration step is completed.

### 3.9.2 Using the `*OPC` command

The `*OPC` (operation complete) command can also be used to detect the completion of each calibration step. In order to use `*OPC` to detect the end of each calibration step, you must do the following:

1. Enable operation complete by sending `*ESE 1`. The command sets the OPC (operation complete bit) in the standard event enable register, allowing operation complete status from the standard event status register to set the ESB (event summary bit) in the status byte when operation complete is detected.
2. Send the `*OPC` command immediately following each calibration command. For example:

```
:CAL:PROT:VZERO2;*OPC
```

Note that you must include the semicolon (;) to separate the two commands, and that the `*OPC` command must appear on the same line as the command.

3. After sending a calibration command, repeatedly test the ESB (Event Summary) bit (bit 5) in the status byte until it is set. (Use either the `*STB?` query or serial polling to request the status byte.)
4. Once operation complete has been detected, clear OPC status using one of two methods: (1) Use the `*ESR?` query, then read the response to clear the standard event status register, or (2) Send the `*CLS` command to clear the status registers. Note that sending `*CLS` will also clear the error queue and operation complete status.

### 3.9.3 Generating an SRQ on calibration complete

An SRQ (service request) can be used to detect operation complete instead of repeatedly polling the Model 6517A. To use this method, send both `*ESE 1` and `*SRE 32` to the instrument, then include the `*OPC` command at the end of each calibration command line, as covered in paragraph 3.9.2. Clear the SRQ by querying the ESR (using the `*ESR?` query) to clear OPC status, then request the status byte with serial polling or the `*STB?` query.

Refer to your controller's documentation for information on detecting and servicing SRQs.

# 4

## Routine Maintenance

---

### 4.1 Introduction

The information in this section deals with routine type maintenance that can be performed by the operator. This information is arranged as follows:

- 4.2 Line voltage selection:** Describes how to select the correct line voltage.
- 4.3 Line fuse replacement:** Explains how to replace a blown power line fuse.
- 4.4 INPUT connector cleaning:** Discusses how to clean the INPUT jack should its insulators become contaminated.
- 4.5 Firmware updates:** Recommends a course of action for firmware updates provided by Keithley.

### 4.2 Line voltage selection

The operating voltage is selected using the rear panel SELECTED LINE VOLTAGE switch (see Figure 4-1). Before connecting the Model 6517A to line power, be sure that line voltage selection switch is set for the correct voltage as marked on the rear panel. Settings are as follows:

- 115V: 105-125V (90-110V)
- 230V: 210V-250V (180-220V)

#### CAUTION

**Operating the Model 6517A on an incorrect line voltage may result in instrument damage. If the line voltage setting is changed, the line fuse will also require replacement. See paragraph 4.3.**

### 4.3 Line fuse replacement

#### WARNING

**Disconnect the line cord at the rear panel, and remove all test leads connected to the instrument (front and rear) before replacing the line fuse.**

The power line fuse is accessible from the rear panel, just below the AC power receptacle (see Figure 4-1). Perform the following steps to replace the line fuse:

1. Insert a flat-bladed screwdriver into the slot of the fuse carrier.
2. While pushing in, turn the screwdriver counterclockwise until the spring-loaded fuse carrier releases from the fuse holder.
3. Pull out the fuse carrier and replace the fuse with the type specified in Table 4-1.

#### CAUTION

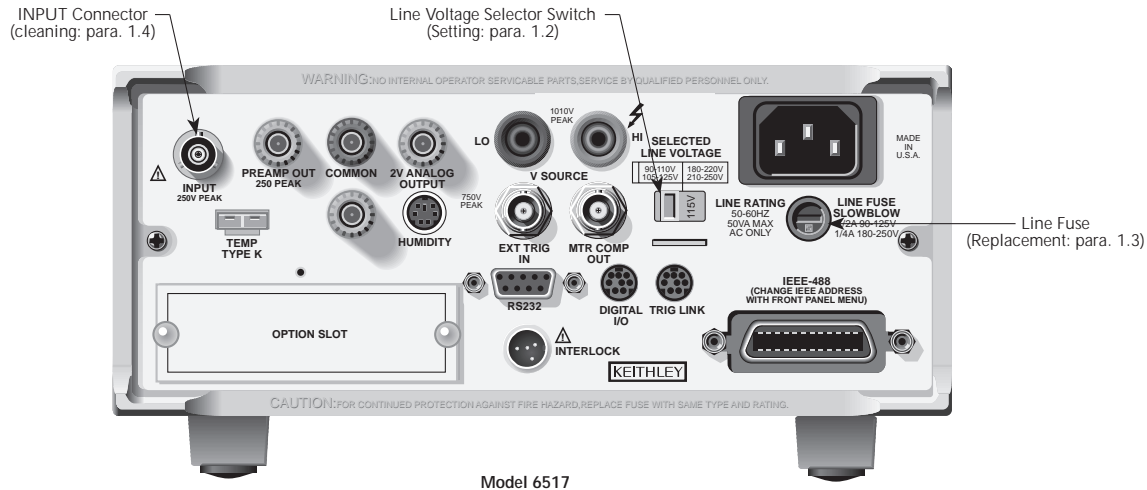
**To prevent instrument damage, use only the fuse type specified in Table 4-1.**

4. Reinstall the fuse carrier.

#### NOTE

If the power line fuse continues to blow, a circuit malfunction exists and must be corrected. Refer to the troubleshooting section of this manual for additional information.





**Figure 4-1**  
Rear panel

**Table 4-1**  
Power line fuse

Line voltage	Rating	Keithley part no.
90-125V	250V, 1/2A, Slow Blow	FU-71
180-250V	250V, 1/4A, Slow Blow	FU-96-4

Note: 5 × 20mm fuses required

#### 4.4 INPUT connector cleaning

The INPUT connector insulators may become contaminated, either through touching, or from air-borne deposits. Such contamination may reduce the input impedance of the Model 6517A, affecting high-impedance and low-current measurements.

If the INPUT connector insulators become contaminated, they should be cleaned using a small foam swab dipped in clean methanol. After cleaning, blow dry with dry nitrogen or allow the connector to dry for several hours in a 50°C, low-humidity environment before use. To avoid further contamination after cleaning, keep the connecting cable or the dust cap on the INPUT connector at all times.

#### 4.5 Firmware updates

It is possible that you may receive a firmware update from Keithley to enhance operation. The firmware for the main microprocessor is contained in two ROMs (U637 and U638) installed in sockets on the digital board to make replacement relatively easy.

The replacement procedure requires that the case cover be removed, and these static-sensitive devices require special handling. As a result, the firmware update procedure should be performed only by qualified service personnel. The procedure to replace the ROMs is located in paragraph 6.7.

# 5

## Troubleshooting

---

### 5.1 Introduction

This section of the manual will assist you in troubleshooting the Model 6517A. Included are self-tests, troubleshooting tables, and circuit descriptions. It is left to the discretion of the repair technician to select the appropriate tests and documentation needed to troubleshoot the instrument. Note that disassembly drawings are located at the end of Section 6, while component layout drawings may be found at the end of Section 7.

#### WARNING

**The information in this section is intended for qualified service personnel. Some of these procedures may expose you to hazardous voltages. Do not perform these hazardous procedures unless you are qualified to do so.**

This section is arranged as follows:

- 5.2 Repair considerations:** Covers some considerations that should be noted before making any repairs to the Model 6517A.
- 5.3 Power-on test:** Describes the tests that are performed on its memory elements each time the instrument is turned on.
- 5.4 Front panel tests:** Provides the procedures to test the functionality of the front panel keys and the display.
- 5.5 Principles of operation:** Gives an overview of operating principles for the analog board, digital board, display board, and power supply.
- 5.6 Circuit board checks:** Summarizes basic tests for the various circuit boards to aid in troubleshooting.

### 5.2 Repair considerations

Before making any repairs to the Model 6517A, be sure to read the following considerations.

#### CAUTION

**The PC boards are built using surface mount techniques and require specialized equipment and skills for repair. If you are not equipped and/or qualified, it is strongly recommended that you send the unit back to the factory for repairs or limit repairs to the PC board replacement level (see following NOTE). Without proper equipment and training, you could damage a PC board beyond repair.**

#### NOTE

For units that are out of warranty, completely assembled PC boards can be ordered from Keithley to facilitate repairs.

1. Repairs will require various degrees of disassembly. Disassembly instructions for the Model 6517A are located in Section 6 of this manual.
2. Do not make repairs to surface mount PC boards unless equipped and qualified to do so (see previous CAUTION).
3. When working inside the unit and replacing parts, be sure to adhere to the handling precautions and cleaning procedures explained in paragraph 6.2.
4. Many CMOS devices are installed in the Model 6517A. These static-sensitive devices require special handling as explained in paragraph 6.3.

5. Whenever a circuit board is removed or a component is replaced, the Model 6517A must be recalibrated.

### 5.3 Power-on test

During the power-on sequence, the Model 6517A will perform a checksum test on its ROMs (U637 and U638) and test its RAM ( U635 and U636). A ROM OK or RAM OK message will be displayed upon successful completion. However, if one of these tests fail, the instrument may lock up completely.

### 5.4 Front panel tests

There are three front panel tests; one to test the functionality of the front panel keys, and two to test the display. In the event of a test failure, refer to paragraphs 5.5.1 and 5.6.1 for details on troubleshooting the display board.

#### 5.4.1 KEYS test

The KEYS test allows you to check the functionality of each front panel key. Perform the following steps to run the KEYS test.

1. Display the MAIN MENU by pressing the MENU key.
2. Select TEST, and press ENTER to display the SELF-TEST MENU.
3. Select FRONT-PANEL-TESTS, and press ENTER to display the following menu:  
FRONT PANEL TESTS  
KEYS DISPLAY-PATTERNS CHAR-SET
4. Select KEYS, and press ENTER to start the test. When a key is pressed, the label name for that key will be displayed to indicate that it is functioning properly. When the key is released, the message "No keys pressed" is displayed.
5. Pressing EXIT tests the EXIT key. However, the second consecutive press of EXIT aborts the test and returns the instrument to the SELF-TEST MENU. Continue pressing EXIT to back out of the menu structure.

#### 5.4.2 DISPLAY PATTERNS test

The display test allows you to verify that each pixel and annunciator in the vacuum fluorescent display is working properly. Perform the following steps to run the display test:

1. Display the MAIN MENU by pressing the MENU key.

2. Select TEST, and press ENTER to display the SELF-TEST MENU.
3. Select FRONT-PANEL-TESTS, and press ENTER to display the following menu:

```
FRONT PANEL TESTS  
KEYS DISPLAY-PATTERNS CHAR-SET
```

4. Select DISPLAY-PATTERNS, and press ENTER to start the display test. There are five parts to the display test. Each time a front panel key (except EXIT) is pressed, the next part of the test sequence is selected. The five parts of the test sequence are as follows:
  - a. Checkerboard pattern (alternate pixels on) and all annunciators.
  - b. Checkerboard pattern and the annunciators that are on during normal operation.
  - c. Horizontal lines (pixels) of the first digit are sequenced.
  - d. Vertical lines (pixels) of the first digit are sequenced.
  - e. Each digit (and adjacent annunciator) is sequenced. All the pixels of the selected digit are on.
5. When finished, abort the display test by pressing EXIT. The instrument returns to the SELF-TEST MENU. Continue pressing EXIT to back out of the menu structure.

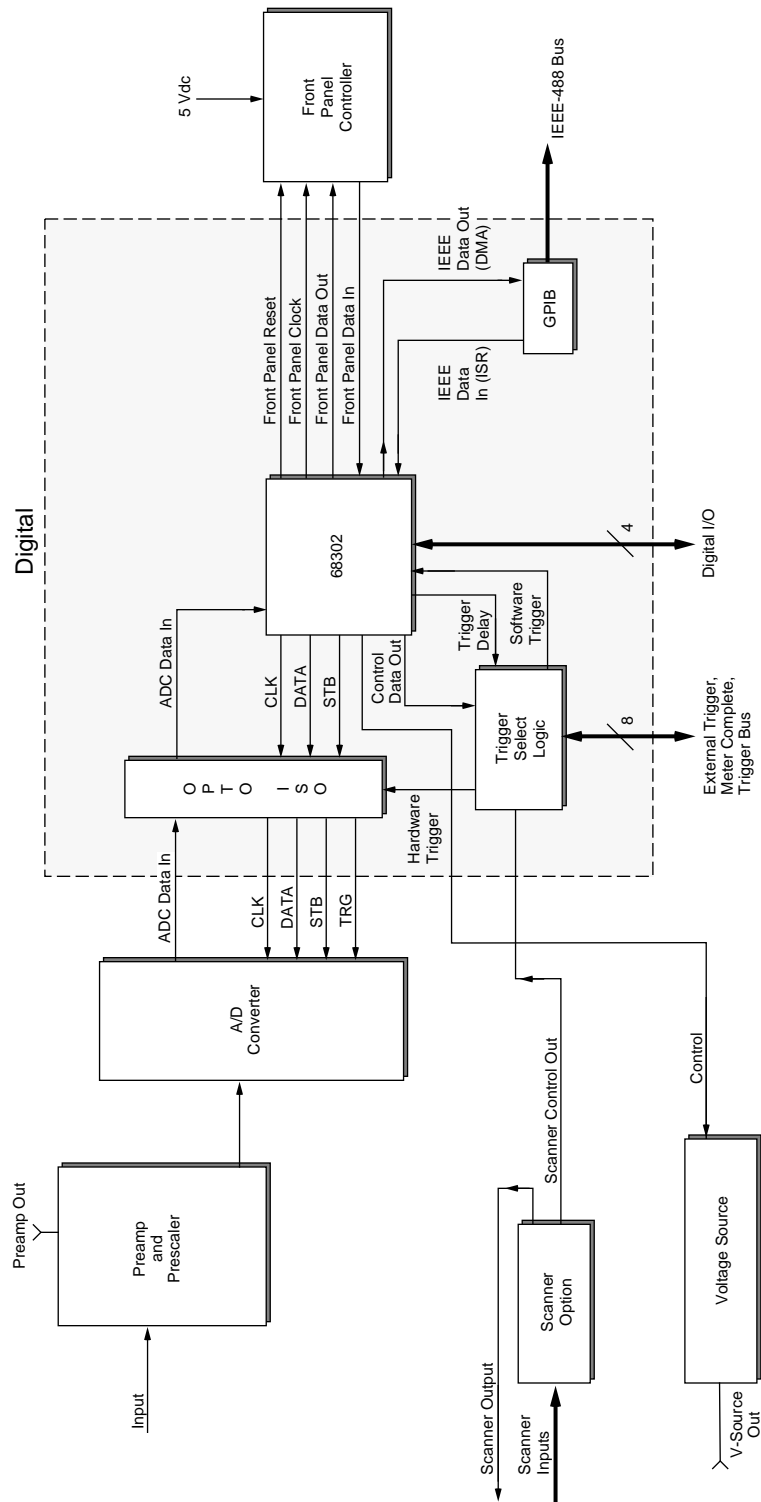
#### 5.4.3 Character set test

You can also display the character set as follows:

1. Display the MAIN MENU by pressing the MENU key.
2. Select TEST, and press ENTER to display the SELF-TEST MENU.
3. Select FRONT-PANEL-TESTS, and press ENTER to display the following menu:  
FRONT PANEL TESTS  
KEYS DISPLAY-PATTERNS CHAR-SET
4. Select CHAR-SET, and press ENTER to display the character set.
5. Press any key except EXIT to cycle through the character set displays.
6. Press EXIT to halt the test and return to the self-test menu.

### 5.5 Principles of operation

The following paragraphs provide a brief overview of operating principles for each major circuit section of the Model 6517. Figure 5-1 shows an overall block diagram of the instrument.



**Figure 5-1**  
Model 6517A overall block diagram

### 5.5.1 Display board

The following information provides some basic circuit theory that can be used as an aid to troubleshoot the display and keyboard. Figure 5-2 shows a block diagram of the display board.

#### Display microcontroller

U902 is the display microcontroller that controls the VFD (vacuum fluorescent display) and interprets key data. The microcontroller has four peripheral I/O ports that are used for the various control and read functions.

Display data is serially transmitted to the microcontroller from the digital board via the TXB line to the microcontroller PD0 terminal. In a similar manner, key data is serially sent back to the digital board through the RXB line via PD1. The 4MHz clock for the microcontroller is generated on the digital board.

#### Vacuum fluorescent display

DS901 is the VFD (vacuum fluorescent display) module, which can display up to 49 characters. Each character is organized as a 5 × 7 matrix of dots or pixels and includes a long under-bar segment to act as a cursor.

The display uses a common multiplexing scheme with each character refreshed in sequence. U903 and U904 are the grid drivers, while U901 and U905 are the dot drivers. Note that dot driver and grid driver data is serially transmitted from the microcontroller (PD3 and PC1).

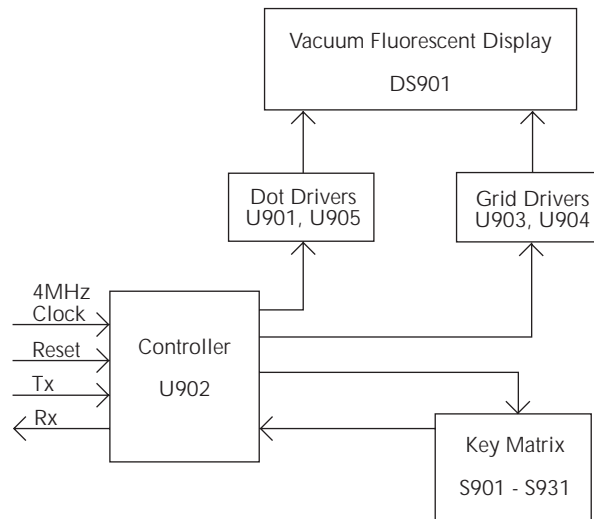
The VFD requires both +60VDC and 5VAC for the filaments. These VFD voltages are supplied by T601, which is located on the digital board.

#### Key matrix

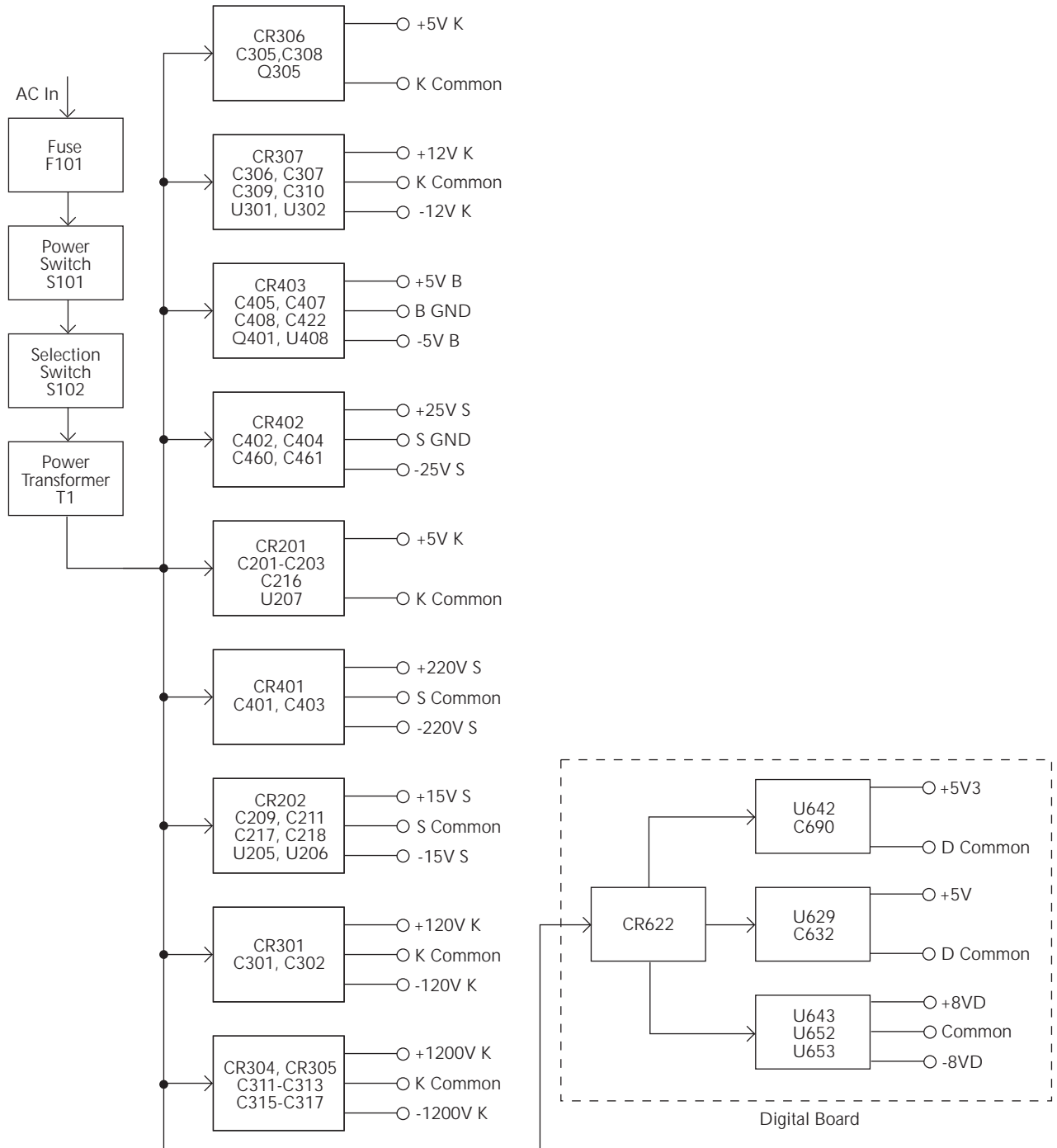
The front panel keys (S901-S931) are organized into a row-column matrix to minimize the number of microcontroller peripheral lines required to read the keyboard. A key is read by strobing the columns and reading all rows for each strobed column. Key down data is interpreted by the display microcontroller and sent back to the main microprocessor using proprietary encoding schemes.

### 5.5.2 Power supply

The following information provides some basic circuit theory that can be used as an aide to troubleshoot the power supply. Figure 5-3 shows a block diagram of the power supply.



**Figure 5-2**  
Display board block diagram



**Figure 5-3**  
Power supply block diagram

### Line power circuits

AC power is applied to the AC receptacle J1001 through the fuse F101, line switch S101, and line voltage selection switch S103 to the power transformer T1. The power transformer has a total of 10 secondary windings for the various DC supplies in the instrument.

### DC circuits

Numerous DC supplies generate power for the various circuits within the instrument. Each supply uses a bridge rectifier and capacitive filter arrangement, and many supplies are regulated. Table 5-1 summarizes rectifier, filter, and regulator circuits for the various DC supplies.

**Table 5-1**  
Power supply circuits

Supply	Rectifier	Filter	Regulator
+5VK	CR306	C305, C308	Q305
+12VK	CR307	C307, C309	U301
-12VK	CR307	C306, C310	U302
+120VK	CR301	C302	N/A
-120VK	CR301	C301	N/A
+1200VK	CR304	C311-C313	N/A
-1200VK	CR305	C315-C317	N/A
+5VB	CR403	C407, C408	U408
-5VB	CR403	C422	Q401
+25VS	CR402	C404, C461	N/A
-25VS	CR402	C402, C460	N/A
+5VS	CR201	C201-C203	U207
+220VS	CR401	C401	N/A
-220VS	CR401	C403	N/A
+15VS	CR202	C211, C217	U206
-15VS	CR202	C209, C218	U205

### 5.5.3 Digital board

The various sections of the digital board are discussed below. Figure 2-4 shows a block diagram of the digital board.

#### Microprocessor

U631 is a 68302 microprocessor that oversees all operating aspects of the instrument. The MPU has a 16-bit data bus and a 21-bit address bus, as well as parallel and serial ports for controlling various circuits. For example, the RXD1 and TXD1 lines are used for the RS-232 interface.

The MPU clock frequency of 16MHz is controlled by crystal Y602. MPU power-on reset is performed by U639, which holds the MPU RESET line low briefly on power-up.

### Memory circuits

ROMs U637 and U638 store the code for instrument operation. U637 stores the D0-D7 bits of each word, and U638 stores the D8-D15 bits. Note that the digital board includes provisions for selecting between flash memory and conventional EPROMs; memory type selection is performed by jumpers W607-W610.

RAMs U635 and U636 provide temporary operating storage. U635 stores the D0-D7 bits of each data word, and U636 stores the D8-D15 bits.

Semi-permanent storage facilities include NVRAM U634 and battery backed-up RAM U640. These two ICs store such information as instrument setup and calibration constants. Note that data transmission to and from these devices is done in serial fashion. Also, U640 generates the 32.768kHz clock required to time serial data transmission with the aid of crystal Y604.

#### A/D converter interface

A/D converter control and data transmission is performed serially through buffer IC U614. Note that data transmission and reception is controlled by various MPU serial and parallel port lines. A/D converter communication lines include: A/D\_TRIG, used to trigger the A/D; A/D\_STB, used to strobe A/D control data, and A/D\_DATA, which receives A/D converter counts from the A/D converter.

#### RS-232 interface

Serial data transmitting and receiving is performed by the TXD1 and RXD1 lines of the MPU itself.

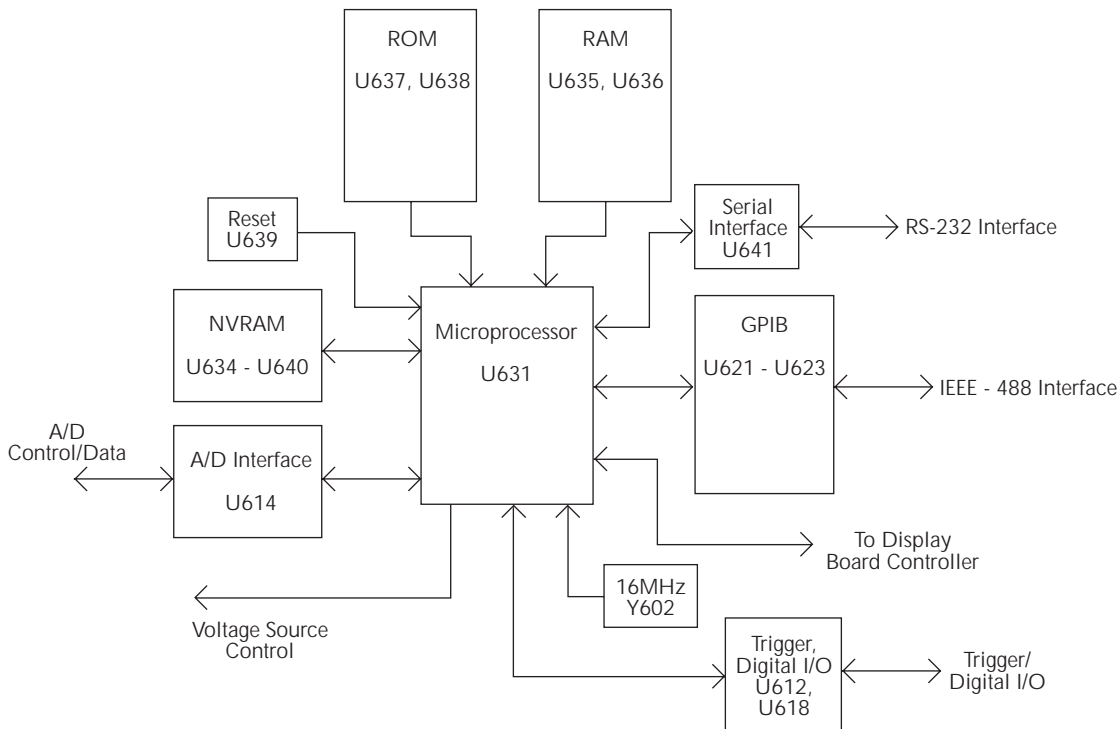
U641 provides the necessary voltage level conversion for the RS-232 interface port.

#### IEEE-488 interface

U621-U623 make up the IEEE-488 interface. U622, a 9914A GPIA, takes care of routine bus overhead such as handshaking, while U621 and U623 provide the necessary buffering and drive capabilities.

#### Trigger and digital I/O circuits

U612 provides buffering for the digital I/O lines, while U618 provides similar functions for the trigger link, external trigger, and voltmeter complete trigger lines. In addition to buffering, U618 also has additional logic that minimizes MPU overhead necessary to control the various trigger lines.



**Figure 5-4**  
Digital board block diagram

Both the digital I/O and trigger link circuits have protection circuits to prevent damage from external circuits. CR603, CR605, CR607, and CR609 protect the digital I/O circuits, while the various trigger lines are protected by CR611-CR618, as well as by CR635-CR639 and CR642.

**Power supply circuits**

While most power supply circuits are located on the analog board, several supplies are located on the digital board. These include the +5V3, +5V, line frequency, and VFD power supply circuits.

AC voltage from the power transformer is rectified by CR622 and filtered by C611. U642 regulates the +5V3 supply, and U629 regulates the +5V supply. The square wave line frequency signals LINEFREQ1 and LINEFREQ2 are generated by U628 and associated components. The MO-30 power supply module generates the voltages necessary to operate the VFD located on the display board, while, U643, U652, and U653 generate the +8VD and -8VD supply voltages.

**5.5.4 Analog board**

Figure 5-5 is a block diagram of the analog board. Various sections of the analog board are covered below with the exception of the power supply circuits, which are covered separately paragraph 5.5.2.

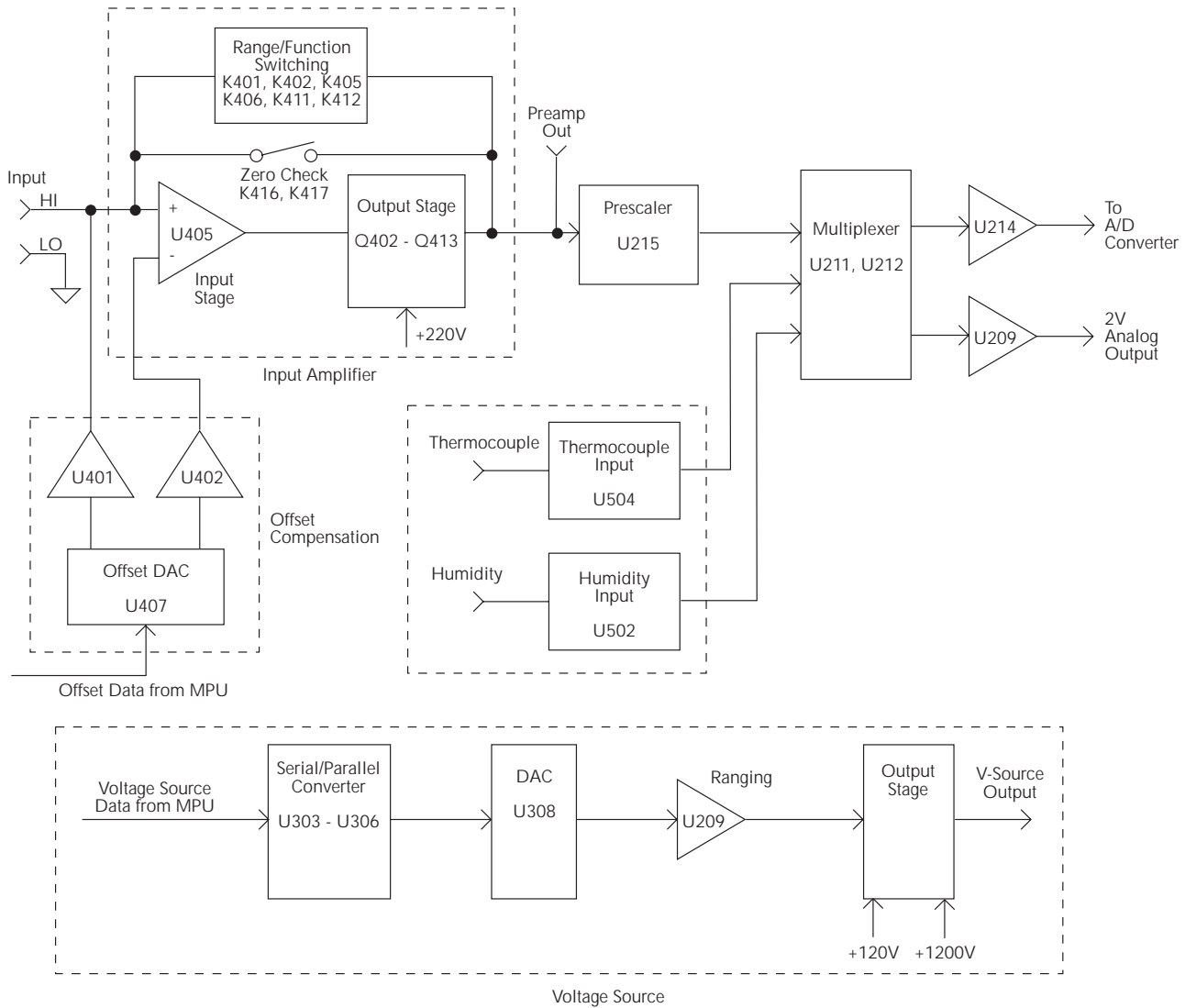
**Input preamplifier**

The input preamplifier stage provides the high input impedance necessary for the voltage function, as well as the low input bias current and current- or charge-to-voltage conversion for the amps, ohms, and coulombs functions. The input preamplifier is essentially made up of three sections: the input stage, range/function switching, and the output stage.

The input stage is made up of U405 and associated components. This IC has the required low input bias current, and it also provides the overall gain for the input preamplifier.

The output stage includes Q402-Q413 and associated components. This stage supplies the necessary voltage and current drive capability for the input preamplifier.

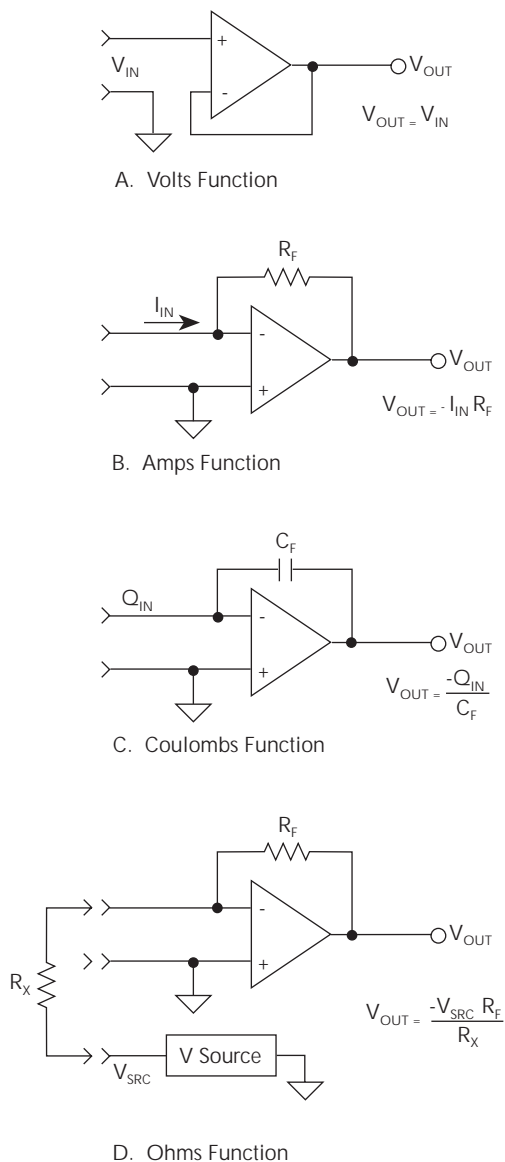




**Figure 5-5**  
Analog board block diagram

Range/function switching is performed by various relays and associated components. These relay contacts control the circuit elements placed in the feedback path of the input preamplifier. For example, in the amp and ohm functions, appropriate feedback resistors are placed in the feedback path, while capacitors are used as the feedback element in the coulombs function. In the volts function, the preamp is configured as a unity-gain buffer by connecting its output node to the inverting input.

The input preamplifier is actually a compound operation amplifier whose exact configuration depends on the selected measuring function. As shown in Figure 5-6, the preamp is configured as a unity-gain buffer in the volts function, as an I-V converter in the amp and ohm functions, and as a Q-V converter in the coulombs function.



**Figure 5-6**  
Preamp configurations

**Offset compensation**

Although the input preamplifier has low offset voltage and input bias current, offset compensation circuitry is included to further diminish any residual offsets. The offset compensation circuitry consists of a DAC and buffer amplifiers.

During the offset correction process, offset parameters are read by the MPU, and offset compensation constants are calculated and stored for reference. During normal operation, serial offset compensation data from the MPU is

converted into parallel data by U403 and U404, and fed to a 12-bit DAC, U407. After the digital-to-analog conversion process, offset signals are buffered by U401 and U402 and applied to appropriate nodes of the preamplifier input stage to null offsets.

**Prescaler**

A prescaler circuit, made up of U215 and various feedback elements, selects the overall signal gain depending on selected range and function. Analog switches located in U210 and U211 select among the six feedback resistors R219-R224 to set the U215 gain factor. Prescaler absolute voltage gains of  $\times 0.05$ ,  $\times 0.5$ , and  $\times 5$  are available depending on the pair of feedback resistors selected.

**2V analog output**

The 2V analog output provides a 0-2V output voltage analogous to the input signal. U209 is the 2V analog output buffer amplifier, and R214 and R215 set the absolute gain of U209 to  $\times 0.2$ .

**Multiplexer**

Elements of U211 and U212 form the signal multiplexer that switches among the various signals to be applied to the A/D converter input. In addition to the preamp, temperature, and humidity signals, the multiplexer also switches among reference and zero signals at various phases of the measurement cycle.

**A/D input buffer**

The A/D input buffer U214 is the final circuit used to process the signal before it is applied to the A/D converter input. Note that the voltage gain of U214 is set to unity.

**Temperature and humidity circuits**

Both the temperature and humidity inputs require additional buffering and amplification. U504 and associated components provides these functions for the temperature input, while U502 and corresponding components perform similar functions for the humidity input.

Since both the temperature and humidity input voltages are referenced to digital common, special circuits are necessary to isolate the analog and digital sections. U501 and one-half of U213 provide the necessary isolation for the humidity signal, while U503 and the other half of U213 isolate the temperature signal.

## Voltage source

The various voltage source circuits include the digital interface, the DAC, range control, and the power output stage. Each of these sections is briefly discussed below.

Serial voltage source control information is converted into parallel form by U303-U306. U304 is a latch that stores range and operate information, while U305 and U306 store the 16-bit data word for the voltage source output value.

The 16-bit data word that represents the voltage source value is converted into analog form by U308, a 16-bit DAC. The voltage reference for U308 is generated by regulator U309.

The voltage source itself is actually a compound operational amplifier. U307 provides the overall stage gain, while power output capabilities are supplied by Q311-Q317. Note that the  $\pm 120\text{V}$  supply is used to power the output stage on the 100V range, while the  $\pm 1200\text{V}$  supply powers the output stage on the 1000V range.

Voltage source ranging is provided by selecting feedback resistor values with elements of U312. Approximate voltage gain on the 100V range is  $\times 20.5$ , while the 1000V range gain is  $\times 207.9$ .

## 5.6 Circuit board checks

Basic troubleshooting checks for the various circuit boards are covered below.

### 5.6.1 Display board checks

If the FRONT PANEL TESTS (paragraph 5.4) indicate that there is a problem on the display board, use Table 5-2. Circuit theory for the display is provided in paragraph 5.5.1.

**Drawing reference: Display Board; 2002-110**

**Table 5-2**  
*Display board checks*

Step	Item/component	Required condition	Remarks
1	FRONT PANEL TESTS	Verify that all pixels operate	Use SELF-TEST MENU selection
2	P1033, pin 5	+5V, $\pm 5\%$	Digital +5V supply
3	CR902 cathode	+60V, $\pm 10\%$	VFD +60V supply
4	P1033, pin 12	Goes low briefly on power-up, then goes high	Microcontroller RESET line
5	U902, pin 43	4MHz square wave	Controller 4MHz clock
6	P1033, pin 10	Pulse train every 1msec	Control from main processor
7	P1033, pin 8	Brief pulse train when front panel key pressed.	Key down data sent to main processor.

## 5.6.2 Power supply checks

Power supply problems can be checked out using Table 5-3.

**Drawing reference: Analog Board; 6517-100**

### WARNING

**Some power supply voltages are hazardous. Use caution to avoid electrical shock that may result in personal injury or death.**

**Table 5-3**

*Power supply checks*

Step	Item/component	Required condition	Remarks
1	F101 line fuse	Check continuity	Remove to check
2	Line switch	115V/230V as required.	Line voltage selection switch.
3	Line power	Plugged into live receptacle, power on	Check for correct power up sequence.
4	Q305, pin 1	+5V, $\pm 5\%$	Referenced to Common K (U301 pin 2)
5	U301, pin 1	+12V, $\pm 5\%$	Referenced to Common K.
6	U302, pin 3	-12V, $\pm 5\%$	Referenced to Common K.
7	+120VK (VR301 anode)	110V to 130V	Referenced to Common K.
8	-120VK (VR302 cathode)	-110V to -130V	Referenced to Common K.
9	+1200VK (VR303 anode)	1100V to 1300V	Referenced to Common K.
10	-1200VK (VR304 cathode)	-1100V to -1300V	Referenced to Common K.
11	+5VB (U408 pin 3)	+5V, $\pm 5\%$	Referenced to Common B. (BGND, U408 pin 2)
12	-5VB (Q401 pin 3)	-5V, $\pm 5\%$	Referenced to Common B.
13	+25VS (C461 +)	22V to 28V	Referenced to Common S. (SGND, U207 pin 2)
14	-25VS (C460 -)	-22V to -28V	Referenced to Common S.
15	+5VS (U207 pin 3)	+5V, $\pm 5\%$	Referenced to Common S.
16	+220VS (C401 +)	200V to 240V	Referenced to Common S.
17	-220VS (C403 -)	-200V to -240V	Referenced to Common S.
18	+15VS (U206 pin 3)	+15V, $\pm 5\%$	Referenced to Common S.
19	-15VS (U205 pin 3)	-15V, $\pm 5\%$	Referenced to Common S.

### 5.6.3 Digital board checks

Table 5-4 summarizes checks for the digital board.

**Drawing reference: Digital board; 6517-140**

**Table 5-4**  
*Digital board checks*

Step	Item/component	Required condition	Remarks
1	Power-on test	RAM OK, ROM OK.	Verify that RAM and ROM are functional.
2	U635 pin 16	Digital common.	All signals referenced to digital common.
3	U635 pin 32	+5V	Digital logic supply.
4	U631 pin 92	Low on power-up, then goes high.	MPU RESET line.
5	U631 pins 1-24	Check for stuck bits.	MPU address bus.
6	U631 pins 31-48	Check for stuck bits.	MPU data bus.
7	U631 pin 101	16MHz clock	MPU clock.
8	U639 pin 1	+3V	Backup battery voltage.
9	U640 pin 1	32.768kHz clock	Serial RAM clock.
10	U641 pin 13	Pulse train during RS-232 I/O.	RS-232 RX line.
11	U641 pin 14	Pulse train during RS-232 I/O.	RS-232 TX line.
12	U622 pins 34-42	Pulse train during IEEE-488 I/O.	IEEE-488 data bus.
13	U622 pins 26-31	Pulses during IEEE-488 I/O.	IEEE-488 command lines.
14	U622 pin 24	Low with remote enabled.	IEEE-488 REN line.
15	U622 pin 25	Low during interface clear.	IEEE-488 IFC line.
16	U614 pin 7	Pulse train.	ODATA line.
17	U614 pin 9	Pulse train.	DCLK line.
18	U614 pin 5	Pulse train.	A/D_TRIG line.
19	U614 pin 12	Pulse train.	A/D_TRIG line.
20	U614 pin 18	Pulse train.	A/D_STB line.
21	U642 pin 3	+5V, $\pm 5\%$	+5V3 supply.
22	U629 pin 3	+5V, $\pm 5\%$	+5V supply.
23	U628 pin 7	60Hz square wave.	LINEFREQ signal.

### 5.6.4 Analog board checks

Circuit checks for the analog board are summarized in Table 5-5.

**Drawing reference: Analog Board; 6517-100**

### WARNING

**Some analog board measurements concern hazardous voltages. Use caution to avoid electric shock that may result in personal injury or death.**

**Table 5-5**  
*Analog board checks*

Step	Item/component	Required condition	Remarks
1	Front panel controls	Volts function, 2V range, zero check off.	Initial test conditions.
2	INPUT jack	Apply +2.0000V DC	Input test voltage.
3	PREAMP OUT	+2V	Referenced to COMMON.
4	U215 pin 6	-10V	Referenced to COMMON.
5	2V ANALOG OUTPUT	+2V	Referenced to COMMON.
6	Front panel controls	Volts function, 20V range, zero check off.	Initial test conditions.
7	INPUT jack	Apply +20.0000V DC	Input test voltage.
8	PREAMP OUT	+20V	Referenced to COMMON.
9	U215 pin 6	-10V	Referenced to COMMON.
10	2V ANALOG OUTPUT	+2V	Referenced to COMMON.
11	Front panel controls	Volts function, 200V range, zero check off.	Initial test conditions.
12	INPUT jack	Apply +200.0000V DC	Input test voltage.
13	PREAMP OUT	+200V	Referenced to COMMON.
14	U215 pin 6	-10V	Referenced to COMMON.
15	2V ANALOG OUTPUT	+2V	Referenced to COMMON.
16	Front panel controls	Amps function, 20pA range, zero check off.	Initial test conditions.
17	INPUT jack	Apply +20.0000pA DC	Input test current.
18	PREAMP OUT	+20V	Referenced to COMMON.
19	U215 pin 6	-10V	Referenced to COMMON.
20	2V ANALOG OUTPUT	+2V	Referenced to COMMON.
21	Front panel controls	Amps function, 20nA range, zero check off.	Initial test conditions.
22	INPUT jack	Apply +20.0000nA DC	Input test current.
23	PREAMP OUT	+20V	Referenced to COMMON.
24	U215 pin 6	-10V	Referenced to COMMON.
25	2V ANALOG OUTPUT	+2V	Referenced to COMMON.
26	Front panel controls	Amps function, 20μA range, zero check off.	Initial test conditions.
27	INPUT jack	Apply +20.0000μA DC	Input test current.
28	PREAMP OUT	+20V	Referenced to COMMON.
29	U215 pin 6	-10V	Referenced to COMMON.
30	2V ANALOG OUTPUT	+2V	Referenced to COMMON.
31	Front panel controls	Amps function, 20mA range, zero check off.	Initial test conditions.
32	INPUT jack	Apply +20.0000mA DC	Input test current.
33	PREAMP OUT	+20V	Referenced to COMMON.
34	U215 pin 6	-10V	Referenced to COMMON.
35	2V ANALOG OUTPUT	+2V	Referenced to COMMON.
36	Front panel controls	Coulombs function, 2nC range, zero check off.	Initial test conditions.
37	INPUT jack	Apply 2nC charge.	Input test charge.
38	PREAMP OUT	+20V	Referenced to COMMON.
39	U215 pin 6	-10V	Referenced to COMMON.

**Table 5-5**

Analog board checks (cont.)

Step	Item/component	Required condition	Remarks
40	2V ANALOG OUTPUT	+2V	Referenced to COMMON.
41	Front panel controls	Coulombs function, 20nC range, zero check off.	Initial test conditions.
42	INPUT jack	Apply 20nC charge.	Input test charge.
43	PREAMP OUT	+20V	Referenced to COMMON.
44	U215 pin 6	-10V	Referenced to COMMON.
45	2V ANALOG OUTPUT	+2V	Referenced to COMMON.
46	Front panel controls	Set voltage source to 100V, operate on.	Program voltage source.
47	U308 pin 4	4.88V	Referenced to V SOURCE LO.
48	V SOURCE HI	100V	Referenced to V SOURCE LO.
49	Front panel controls	Set voltage source to 100V, operate on.	Program voltage source.
50	U308 pin 4	4.81V	Referenced to V SOURCE LO.
51	V SOURCE HI	1000V	Referenced to V SOURCE LO.
52	Q311 drain	+1200V	Referenced to V SOURCE LO.
53	CR302 cathode	+120V	Referenced to V SOURCE LO.
54	VR311 anode	-1200V	Referenced to V SOURCE LO.
55	CR308 cathode	-120V	Referenced to V SOURCE LO.

# 6

## Disassembly

---

### 6.1 Introduction

The information in this section explains how to disassemble the Model 6517A. Also discussed are handling and cleaning considerations as well as the procedure to change the main CPU firmware in the event of an upgrade.

#### WARNING

**The information in this section is intended only for qualified service personnel. Some of these procedures may expose you to hazardous conditions. Do not attempt these procedures unless you are qualified to do so.**

This section is organized as follows:

- 6.2 Handling and cleaning precautions:** Covers general precautions to take when troubleshooting inside the unit, and cleaning procedures when replacing parts.
- 6.3 Static-sensitive devices:** Explains handling procedures for static-sensitive devices.
- 6.4 Case cover removal:** Explains how to remove the case cover.
- 6.5 PC board removal:** Provides the procedures for removing the digital board, A/D converter board, and the analog board.
- 6.6 Front panel disassembly:** Explains how to remove the display board.
- 6.7 Main CPU firmware replacement:** Provides the procedure to change firmware.

**6.8 Instrument re-assembly:** Provides some general guidelines to follow when re-assembling the Model 6517A.

**6.9 Assembly drawings:** Provides mechanical drawings to assist in the disassembly and re-assembly of the Model 6517A.

### 6.2 Handling and cleaning precautions

When servicing the instrument, care should be taken not to indiscriminately touch PC board traces to avoid contaminating them with body oils or other foreign matter. Analog board areas covered by the shield have high-impedance devices or sensitive circuitry where contamination could cause degraded performance.

#### 6.2.1 PC board handling

Observe the following precautions when handling PC boards:

- Wear clean cotton gloves.
- Handle PC boards only by the edges and shields.
- Do not touch any board traces or components not associated with the repair.
- Do not touch areas adjacent to electrical contacts.
- Use dry nitrogen gas to clean dust off PC boards.



## 6.2.2 Solder repairs

Observe the following precautions when it is necessary to use solder on a circuit board:

- Use an OA-based (non-acid) flux, and take care not to spread the flux to other areas of the circuit board.
- Remove the flux from the work areas when the repair has been completed. Use pure water along with clean foam-tipped swabs or a clean soft brush to remove the flux. Be sure not to wash contaminated flux or water over other PC board areas.
- Once the flux has been removed, swab only the repaired area with methanol, then blow dry the board with dry nitrogen gas.
- After cleaning, the board should be allowed to dry in a 50°C low-humidity environment for several hours.

## 6.3 Special handling of static-sensitive devices

CMOS devices operate at very high impedance levels for low power consumption. As a result, any static that builds up on your person or clothing may be sufficient to destroy these devices, if they are not handled properly. Use the following precautions to avoid damaging them:

### CAUTION

**Many CMOS devices are installed in the Model 6517A. In general, it is recommended that all semiconductor devices be handled as being static-sensitive.**

1. ICs should be transported and handled only in containers specially designed to prevent static build-up. Typically, these parts will be received in anti-static containers of plastic or foam. Keep these devices in their original containers until ready for installation.
2. Remove the devices from their protective containers only at a properly grounded work station. Also, ground yourself with a suitable wrist strap.
3. Handle the devices only by the body; do not touch the pins.
4. Any printed circuit board into which the device is to be inserted must also be grounded to the bench or table.
5. Use only anti-static type solder sucker.
6. Use only grounded tip solder irons.
7. Once the device is installed in the PC board, it is usually adequately protected, and normal handling can resume.

## 6.4 Case cover removal

If it is necessary to troubleshoot the instrument or to replace a component, use the following procedure to remove the case cover.

### WARNING

**Before removing the case cover, disconnect the line cord and any connecting cables and wires from the instrument. Allow sufficient time for capacitors to discharge before disconnecting cables or removing the cover.**

To remove the case cover, refer to drawing 6517A-057 (at the end of this section), and perform the following steps:

1. Remove handle: The handle serves as an adjustable tilt-bail. Its position is adjusted by gently pulling it away from the sides of the instrument case and swinging it up or down. To remove the handle, swing the handle below the bottom surface of the case and back until the orientation arrows on the handles line up with the orientation arrows on the mounting ears. With the arrows lined up, pull the ends of the handle out of the case.
2. Remove mounting ears: Each mounting ear is secured to the chassis with a single screw. Remove the two screws, and pull down and out on each mounting ear. Note: When re-installing the mounting ears, make sure to mount the right ear to the right side of the chassis, and the left ear to the left side of the chassis. Each ear is marked "RIGHT" or "LEFT" on its inside surface.
3. Remove rear bezel: The rear bezel is secured to the chassis by two screws. To remove the rear bezel, loosen the two screws and pull the bezel away from the case.
4. Remove grounding screw: Remove the grounding screw for the case cover. This screw is located on the bottom side of the instrument at the rear.
5. Remove chassis: Grasp the front bezel of the instrument and carefully slide the chassis forward out of the metal case.

The internal PC board assemblies are now accessible.

## 6.5 PC board removal

There are three PC boards mounted in the chassis: the digital board, the analog board, and the A/D converter board, which is mounted on the analog board. The removal of these three boards is covered below. The display board is mounted in the

front panel assembly. The removal of the display board is covered in paragraph 6.6.

Any one of the PC boards can be removed without having to remove any of the other boards. Note that the A/D converter board plugs into the analog board and can be left installed when removing the analog board.

#### NOTE

Before performing any of the following procedures to remove a PC board, remove the case cover as explained in paragraph 6.4.

### 6.5.1 Digital board removal

The digital board is removed through the bottom of the chassis (see drawing 6517-053). Note that the power switch pushrod need not be removed in order to remove the digital board.

Perform the following steps to remove the digital board:

1. Unplug cables: Turn the chassis upside-down and unplug the following cables from the digital board:
  - a. Unplug the display board ribbon cable from connector J1033.
  - b. Unplug the transformer cable from connector J1032.
  - c. Unplug the analog board ribbon cable from connector J1029. This cable connection is located under the power switch pushrod.
  - d. Unplug the interlock cable from connector J1030. This four-conductor cable connection is located at the rear of the digital board in front of the IEEE-488 connector.
2. Unfasten PC board: Remove the following items to unfasten the digital board from the chassis:
  - a. At the rear panel, remove the nuts that secure the IEEE-488 and RS-232 connectors to the chassis.
  - b. Remove the clip that secures regulators U629 and U642 to the chassis. This clip is located adjacent to the pushrod near the front panel.
  - c. Remove the three screws that secure the digital board to the chassis. One screw is located at the rear of the digital board near the interlock connector, and the other two screws are located near the connector for the option slot.
3. Remove digital board: The board is held in place by edge guides on each side. Slide the digital board forward until the board edges clear the guides, and then carefully pull the board out of the chassis.

### 6.5.2 A/D converter board removal

The A/D converter board is located under the A/D Board shield on the analog board (see drawing 6517A-050).

Perform the following steps to remove the A/D converter board:

1. Remove A/D board shield: Position the chassis right-side-up. The A/D board shield is secured to the analog board by two screws. To remove the shield, simply remove the screws and carefully lift the shield away from the A/D converter board.
2. Remove A/D converter board: The A/D converter board is located near the front of the instrument and is plugged into the analog board at connector J1026. The board rests on three stand-offs, one of which has a retaining clip to hold the board securely in place. Gently pull the retaining clip away and lift the board up until it clears the clip. With the board clear of the retaining clip, unplug the board and pull it out of the chassis.

### 6.5.3 Analog board removal

The analog board is removed through the top of the chassis (see drawing 6517-053). Perform the following steps to remove the analog board:

1. Remove analog top shield: The top shield is secured to the analog board by a single screw. To remove the top shield, simply loosen the screw and carefully lift the shield out of the chassis.
2. Remove pushrod: Remove the pushrod for the POWER switch as follows:
  - a. Turn the chassis upside-down. Grasp the rear end of the POWER pushrod, and pull upward until it disengages from the switch shaft. Remove the pushrod from the chassis.
  - b. Return the chassis to the up-right position.
3. Remove power transformer: Remove the power transformer (see drawing 6517A-054) as follows:
  - a. Disconnect the transformer ground. A kepinut is used to connect this green ground wire to a threaded stud on the chassis.
  - b. Unplug the transformer. There are five plugs for the transformer. Four are located on the analog board at connectors J1024, J1025, J1027, and J1028, and the fifth is located on the digital board at connector J1032. Turn the chassis upside-down to gain access to the plug on the digital board. When finished, return the chassis to the up-right position.

- c. The transformer is secured to the bottom of the chassis by four screws. Remove these screws and pull the transformer out of the chassis.
4. Remove AC power receptacle: Remove the AC power receptacle as follows:
  - a. Disconnect the receptacle ground wire. A kep nut is used to connect this green ground wire to a threaded stud on the chassis.
  - b. Unplug the AC power receptacle cable. The connector for this cable is located on the analog board next to the power receptacle.
  - c. A spring clip on each side of the receptacle is used to secure it to the rear panel of the chassis. To remove it, press both clips inward and, at the same time, push the receptacle out of the access hole in the rear panel of the chassis.
5. Unplug cable to digital board: On the left side of the analog board there is a ribbon cable going to the digital board. Turn the chassis upside-down, and unplug this cable at connector J1029 on the digital board. Return the chassis to the right-side-up position.
6. Disconnect input/output cables: Disconnect the following cables from the analog board:
  - a. INPUT cable at J1019 and J1020.
  - b. V SOURCE cable at J1022.
  - c. PREAMP OUT, COMMON, and 2V OUTPUT cable at J1021.
7. Unfasten analog board: The analog board is secured to the chassis at the rear panel by the two BNC connectors (External Trigger and Meter Complete). At the rear panel, remove the nuts and lock washers for the BNC connectors. Also remove the two screws that secure the board to the chassis.
8. Remove analog board: The board is held in place by edge guides on each side of the chassis. Slide the analog board forward until the board edges clear the guides, and then carefully lift the board out of the chassis. The bottom shield on the analog board can be removed by simply pulling it off the board.

## 6.6 Front panel disassembly

Use the following disassembly procedure to remove the display board and/or the pushbutton switch pad. Drawing 6517A-054 shows how the front panel separates from the chassis, and drawing 6517A-040 shows an exploded view of the front panel assembly.

### NOTE

Before performing the following procedure to remove and disassemble the front

panel, remove the case cover as explained in paragraph 6.4.

Perform the following steps to remove and disassemble the front panel:

1. Unplug display cable: Turn the chassis upside-down, and unplug the display cable from the digital board at connector J1033.
2. Remove front panel assembly: The front panel assembly has four retaining clips that snap onto the chassis over four pem nut studs. Two retaining clips are located on each side of the front panel. Pull the retaining clips outward and, at the same time, pull the front panel assembly forward until it separates from the chassis.
3. Remove display board: The display board is held in place by a PC board stop. This stop is simply a plastic bar that runs along the bottom edge of the display board. Using a thin bladed screwdriver, pry the plastic bar upward until it separates from the casing of the front panel. Pull the display board out of the front panel.
4. Remove switch pad: The conductive rubber switch pad simply pulls out of the front panel.

## 6.7 Main CPU firmware replacement

Changing the firmware may be necessary as upgrades become available. The firmware revision level for the main CPU is displayed during the power-on sequence. The firmware for the main CPU is located in two ROMs (U637 and U638) located on the digital board. (See the digital board component layout drawing 6517-140 at the end of Section 4.)

Perform the following steps to replace the CPU firmware:

### WARNING

**Disconnect the instrument from the power line, and disconnect all cables and test leads before changing the firmware.**

1. Remove the case cover as explained in paragraph 6.4.
2. Turn the instrument upside down to gain access to the digital board.
3. Locate U637 and U638 (ROMs) on the digital board. These two ICs are located near the center of the PC board next to the power transformer.

**CAUTION**

**U637 and U638 are static-sensitive devices. Be sure to adhere to the handling precautions explained in paragraph 6.3 when replacing these devices.**

4. Using an appropriate chip extractor, remove U637 and U638 from their sockets.
5. Install the new ROMs in the appropriate sockets, making sure that pin 1 for each device is properly oriented.

**NOTE**

The odd-addressed ROM must be installed at U637, and the even-addressed ROM must be installed at U638. The instrument will not operate if the ROMs are incorrectly installed.

## 6.8 Instrument re-assembly

The instrument can be re-assembled by reversing the previous disassembly procedures. Make sure that all parts are properly seated and secured, and that all connections are properly made. To ensure proper operation, shields must be replaced and fastened securely.

**WARNING**

**To ensure continued protection against electric shock, verify that power line ground (green wire attached to AC power receptacle) and the power transformer ground are connected to the chassis. Also make sure that the external ground screw is properly secured after installing the case cover.**

## 6.9 Assembly drawings

The following assembly drawings are provided to assist in disassembly and re-assembly of the instrument. Also, the Keithley part numbers for most mechanical parts are provided in these drawings.

- Front Panel Assembly; 6517A-040
- Analog Shield Assembly; 6517-050
- Chassis Assembly; 6517-051
- Rear Panel Assembly; 6517-052
- Chassis Assembly (Analog Side); 6517-053
- Chassis Assembly (Front Panel and Transformer Mounting); 6517A-054
- Chassis Assembly (Digital Side); 6517A-055
- Chassis Assembly (Case and Handle); 6517A-057

# 7

## Replaceable Parts

---

### 7.1 Introduction

This section contains replacement parts information and component layout drawings for the Model 6517A.

### 7.2 Parts lists

The electrical parts lists for the Model 6517A are shown in Tables 7-1 to 7-4. For part numbers to the various mechanical parts and assemblies, use the Miscellaneous parts list and the assembly drawings provided at the end of Section 6.

### 7.3 Ordering information

To place an order, or to obtain information concerning replacement parts, contact your Keithley representative or the factory (see inside front cover for addresses). When ordering parts, be sure to include the following information:

- Instrument model number (Model 6517A)
- Instrument serial number
- Part description
- Component designation (if applicable)
- Keithley part number

To facilitate repairs, complete circuit boards are available. Contact the Repair Department (see 7.4) for pricing and availability.

### 7.4 Factory service

If the instrument is to be returned to Keithley Instruments for repair, perform the following:

1. Call the Repair Department at 1-800-552-1115 for a Return Material Authorization (RMA) number.
2. Complete the service form at the back of this manual, and include it with the instrument.
3. Carefully pack the instrument in the original packing carton.
4. Write ATTENTION REPAIR DEPARTMENT and the RMA number on the shipping label.

### 7.5 Component layouts

The component layouts are provided in the following pages:

A/D Converter board: 2001-160  
Display board: 2002-110  
Analog board: 6517-100  
Digital board: 6517-140



**Table 7-1**  
Model 6517A ADC board, parts list

Circuit designation	Description	Keithley part number
	ADC ASSEMBLY	2001-160
	CHOKE 21-030-J	CH-55
	DIODE, ZENER 6.4V, IN4579 (DO-7)	DZ-73-1
	PROGRAM	2001-802*
	SOCKET, 68-PIN QUAD	SO-128-68
C800-803,807,809,815,819,820	CAP, .1UF, 20%, 50V, CERAMIC (1206)	C-418-.1
C804,805	CAP, .1UF, 20%, 50V, CERAMIC (1206)	C-418-.1
C808,818	CAP, 1UF, 20%, 50V, CERAMIC	C-237-1
C812,826-829	CAP, 10UF, 20%, 25V, TANTALUM (D7243)	C-440-10
C814,824	CAP, 10UF, 20%, 25V, TANTALUM (D7243)	C-440-10
C817	CAP, 150PF, 5%, 100V, CERAMIC (0805)	C-465-150P
C821	CAP, .33UF, 10%, 50V, CERAMIC (1812)	C-464-.33
C822,823	CAP, 27PF, 10%, 100V, CERAMIC (1206)	C-451-27P
C825	CAP, .01UF, 10%,100V, POLYPROPYLENE	C-306-.01
C831	CAP, 33PF, 10%, 100V, CERAMIC (1206)	C-451-33P
CR801	DIODE, DUAL SWITCHING, BAV99L(SOT-23)	RF-82
P1026	CONNECTOR, FEMALE 25 PIN	CS-767-25
Q800	TRANS, PNP, MMBT3906L (SOT-23)	TG-244
Q801	TRANS, NPN, MMBT3904 (SOT-23)	TG-238
Q802-806,814	TRANS, N CHAN MOSPOW FET, 2N7000 (TO-92)	TG-195
Q807,809,811	TRANS, SELECTED TG-128 (T0-92)	31841A
Q808,813	TRANS, N CHANNEL JFET, SELECTED J210	TG-167-1
Q810	TRANS, N CHANNEL JFET, 5432 (TO-92)	TG-198
Q812	IC, +5V REGULATOR, 78L05AC (T0-92)	IC-603
R800,813,838	RES, 100K, 5%, 125mW, METAL FILM (1206)	R-375-100K
R801	RES, 475, 1%, 125mW, METAL FILM (1206)	R-391-475
R802-805	RES, 2.21K, 1%, 125mW, METAL FILM (1206)	R-391-2.21K
R806,827	RES, 33.2K, 1%, 125mW, METAL FILM (1206)	R-391-33.2K
R808,859,811,812,862	RES, 10K, 5%, 125MW, METAL FILM(1206)	R-375-10K
R810,820	RES, 2.7K, 5%, 125mW, METAL FILM (1206)	R-375-2.7K
R814	RES, 5.1K, 5%, 125MW, METAL FILM (1206)	R-375-5.1K
R815,829	RES, 82.5, 1%, 125mW, METAL FILM (1206)	R-391-82.5
R818,823	RES, 2.74K, 1%, 1/8W, METAL FILM	R-88-2.74K
R819	RES, 18.7, 1%, 125mW, METAL FILM (1206)	R-391-18.7
R821,822,864	RES, 1K, 5%, 125MW, METAL FILM(1206)	R-375-1K
R824,830	RES, 4.75K, 1%, 125mW, METAL FILM (1206)	R-391-4.75K
R826	RES, 3.92K, 1%, 125mW, METAL FILM (1206)	R-391-3.92K
R828,861	RES, 26.7K, 1%, 125mW, METAL FILM (1206)	R-391-26.7K
R833-836	RES, 1K, .1%, 1/10W, METAL FILM	R-263-1K
R837,846	RES, 19K, .1%, 1/10W, METAL FILM	R-263-19K
R839	RES, 100K, 5%, 125mW, METAL FILM (1206)	R-375-100K

\*Order revision level.

**Table 7-1**  
*Model 6517A ADC board, parts list (cont.)*

<b>Circuit designation</b>	<b>Description</b>	<b>Keithley part number</b>
R840	RES, 40K, .1%, 1/10W, METAL FILM	R-263-40K
R841	RES, 57.8K, .1%, 1/10W, METAL FILM	R-263-57.8K
R842	RES, 920K, .1%, 1/10W, METAL FILM	R-168-920K
R843	RES, 1.2K, .1%, 1/10W, METAL FILM	R-263-1.2K
R844	RES, 4.M, .1% 1/8W, METAL FILM	R-402-4M
R845	RES, 2K, .1%, 1/10W, METAL FILM	R-263-2K
R847	RES, 3.2K, .1%, 1/10W, METAL FILM	R-263-3.2K
R848,851-853	RES, 49.9, 1%, 125mW, METAL FILM (1206)	R-391-49.9
R849,855,858,865	RES, 3.01K, 1%, 125MW, METAL FILM(1206)	R-391-3.01K
R850	RES, 100, 1%, 1/8W, METAL FILM	R-88-100
R854	RES, 1.62K, 1%, 1/8W, METAL FILM	R-88-1.62K
R856,857	RES, 10, 5%, 125MW, METAL FILM(1206)	R-375-10
R860	RES, 150K, 5%, 125MW, METAL FILM (1206)	R-375-150K
R863	RES, 100, 1%, 125mW, METAL FILM (1206)	R-391-100
U800,801	IC, 8 STAGE SHIFT/STORE, MC14094BD (SOIC)	IC-772
U802	IC, OP-AMP, NE5534D (SOIC)	IC-802
U803,804	IC, VOLT COMPARATOR, LM311M (SOIC)	IC-776
U806	IC, VOLT COMPARATOR, LM393D (SOIC)	IC-775
U807	IC, QUAD COMPARATOR, LM339D (SOIC)	IC-774
U809	IC, OP-AMP, OPA602AP	IC-703
U810,811	IC, OP-AMP, LT1097	IC-803
U812	IC, DUAL D-TYPE F/F, 74HC74(SOIC)	IC-773
U813	INTEGRATED CIRCUIT, OPA177GS(SOIC)	IC-960
Y800	OSCILLATOR CMOS, 7.68 MHZ	CR-31



**Table 7-2**  
Model 6517A display board, parts list

Circuit designation	Description	Keithley part number
	BUMPER CLIP, GROUND DISPLAY BOARD ASSEMBLY TAPE, 3/4 WIDE X 1/32 THICK	FE-27A 2001-352B 2002-110 TP-12-1
C901	CAP, 22UF, 20%, 6.3, TANTALUM (C6032)	C-417-22
C902,904,907,908,910	CAP, .1UF, 20%, 100V, CERAMIC (1812)	C-436-.1
C903,905,906,909,911	CAP, .1UF, 20%, 50V, CERAMIC (1206)	C-418-.1
C912	CAP, 2.2UF, 20%, 100V, ALUM ELEC	C-503-2.2
C913,914	CAP, 100UF, 20%, 16V, TANTALUM (7243)	C-504-100
C915,916	CAP, 33PF, 10%, 100V, CERAMIC (1206)	C-451-33P
CR901-904	DIODE, SWITCHING, 250MA, BAV103 (SOD-80)	RF-89
CR905,906	DIODE, SWITCHING, MMBB914 (SOT-23)	RF-83
DS901	VACUUM FLUORESCENT DISPLAY	DD-51C
P1033	CABLE ASSEMBLY	CA-62-4A
Q901,902	TRANS, NPN GEN PURPOSE BC868	TG-293
R901	RES NET, 15K, 2%, 1.875W (SONIC)	TF-219-15K
R902	RES, 13K, 5%, 125MW, METAL FILM (1206)	R-375-13K
R903,904	RES, 4.7K, 5%, 250MW, METAL FILM (1210)	R-376-4.7K
R905	RES, 1M, 5%, 125MW, METAL FILM (1206)	R-375-1M
R906	RES, 1K, 5%, 250MW, METAL FILM (1210)	R-376-1K
R907	RES, 240, 5%, 250MW, METAL FILM (1210)	R-376-240
R908	RES, 10M, 5%, 125MW, METAL FILM (1206)	R-375-10M
T901	TRANSFORMER, TDK, ER14.5 SERIES	TR-300
U901,904,905	IC, LATCHED DRIVERS, UCM-5812EPF-1 (PLCC)	IC-732
U902	PROGRAM	7001-800*
U903	IC, 32-BIT, SERIAL UCN5818EPF-1 (PLCC)	IC-830
VR901	DIODE, ZENER 8.2V, MMBZ5237 (SOT-23)	DZ-92
Y901	CRYSTAL, 4MHZ (SMT)	CR-36-4M

\*Order revision level.

**Table 7-3**  
 Model 6517A analog board, parts list

Circuit designation	Description	Keithley part number
	ANALOG ASSEMBLY	6517-100
	FUSE HOLDER	FH-32
	HEAT SINK	6517-329A
	HEAT SINK	HS-33
	LATCHING HEADER, FRICTION, SINGLE ROW	CS-724-10
	LATCHING HEADER, FRICTION, SINGLE ROW	CS-724-12
C201-203,309,310	CAP, 470UF, 20%, 25V, ALUM ELEC	C-413-470
C204-208,210,212,214,215,263, 264,321,405, 409-413,417,418, 423-428,458,459,440,441	CAP, .1UF, 10%, 25V, CERAMIC (0805)	C-495-.1
C209,211,216,407,422	CAP, 100UF, 20%, 25V, ALUM ELEC	C-413-100
C217,218,305	CAP, 1000UF, +/-20%, 25V, ALUM ELECT	C-413-1000
C219	CAP, 47PF, 5%, 500V, POLYSTYRENE	C-138-47P
C250,251	CAP, .33, .20%, 50V, POLYESTER DIELECTRIC	C-344-.33
C260,261,322,323,338,364-366	CAP, .01UF, 10%, 50V, CERAMIC (0805)	C-491-.01
C262,452	CAP, 10UF, 20%, 25V, TANTALUM (D7243)	C-440-10
C301,302	CAP, 100UF, +/-20%, 200V ALUM ELECT	C-498-100
C303,304	CAP, 2.2UF, +/-20%, 200V ALUM ELECT	C-498-2.2
C306-308,324,331,332	CAP, 10UF, -20+100%, 25V, ALUM ELEC	C-314-10
C311-313,315-317	CAP, 100UF, +/-20%, 450V, ALUM ELECTR	C-499-100
C314,318,330	CAP, .01, 20%, 2000V, CERAMIC	C-324-.01
C319,320,429	CAP, 10PF, 5%, 50V, MONO CERAMIC (0805)	C-452-10P
C333	CAP, 100PF, 10%, 1000V, CERAMIC	C-64-100P
C334	CAP, 33PF, 10%, 1000V, CERAMIC	C-64-33P
C335	CAP, 15PF, 10%, 1000V, CERAMIC	C-64-15P
C336	CAP, 1UF, 20%, 50V, CERAMIC	C-237-1
C337,340-344	CAP, 470PF, 10%, 1000V, CERAMIC	C-64-470P
C339	CAP, 47PF, 10%, 1000V, CERAMIC	C-64-47P
C401,403	CAP, 47UF, +/- 20%, 350V, ALUM ELEC	C-501-47
C402,404,460,461	CAP, 220UF, +/-20%, 50V, ALUM ELEC	C-507-220
C406	CAP, .5PF, 2.5%, 630V, POLYPROPYLEN	C-405-5P
C408	CAP, 2200UF, -20+100%, 25V, ALUM ELEC	C-314-2200
C414	CAP, .001UF, 10%, 100V, POLYESTER	C-511-.001
C416	CAP, 560PF, 2.5%, 630V, POLYPROPYLENE	C-405-560P
C420	CAP, 100PF, 2.5%, 630V, POLYPROPYLENE	C-405-100P
C421	CAP, 10000PF, 5%, 500V, POLYSTYRENE	C-138-10000P
C457	CAP, .0033,20%, 500V, CERAMIC	C-22-.0033
C501,502	CAP, 150PF, 5%, 100V, CERAMIC (0805)	C-465-150P
C550,551	CAP, .01UF, 10%, 200V, CERAMIC (1206)	C-472-.01
CR201,301	DIODE, SILICON, W04M (CASE WM)	RF-46
CR202,306,307,402,403	DIODE, BRIDGE, VM18	RF-52
CR302,303,308	DIODE, HI-VOLTAGE, HV-15	RF-76
CR304,305	DIODE, HI-VOLTAGE	RF-101
CR401	DIODE	RF-104
CR404,408,412,413	DIODE, SILICON, IN4006 (D0-41)	RF-38
CR406,407	DIODE, SILICON, IN4148 (DO-35)	RF-28

**Table 7-3**  
Model 6517A analog board, parts list (cont.)

Circuit designation	Description	Keithley part number
F101	FUSE, .5A, 250V	FU-71
F201	FUSE	FU-100-1
J1002	CONN, MOLEX, 3-PIN	CS-772-3
J1010	CONNECTOR TEMPERATURE	CS-823
J1011	CONN, 6 PIN CIRCULAR DIN	CS-811
J1012,J1013	CONN, BNC	CS-547
J1019,1020	CONN, CONTACT PIN	TE-110
J1021-1023,1028	LATCHING HEADER, FRICTON, SGL ROW	CS-724-3
J1024	CONNECTOR, HEADER	CS-784-6
J1025	MODIFIED BERG HEADER	6517-326-1A
J1026	HEADER, DUAL BODY/STRAIGHT PIN	CS-765-25
J1027	MODIFIED BERG HEADER	6517-326-2A
K301,305,306	RELAY, REED HI VOLT 1FORMA 7301-05-1010	RL-173
K302-304,413,414	RELAY, HIGH VOLT/SOLID STATE LH1056AT	RL-139
K401,402,411,412	RELAY, 1FORMC	RL-175
K405,406,416	RELAY, 1FORMA, COTO 1203-0147	RL-181
K417-419	RELAY, MINI SIGNAL REL	RL-163
P1029	CABLE ASSEMBLY	CA-27-18D
Q301,302,306,307,316,402,409	TRANS, NPN SILICON, 2N3904 (TO-92)	TG-47
Q303,304,308,309,403,404	TRANS, PNP SILICON, 2N3906 (TO-92)	TG-84
Q305	IC, +5V REGULATOR, 78L05AC, (T0-92)	IC-603
Q311,313,315,317	TRANS, C-CHAN MOSFET, 2SK1412 (TO-220ML)	TG-276
Q314	TRANS, N CHAN MOSPOW FET, 2N7000 (TO-92)	TG-195
Q401	IC, -5V REGULATOR, 7905AC (TO-92)	IC-604
Q405,408,410	TRANS, N-CHAN, DMOSFRET, VN0550N3 (TO-92)	TG-283
Q406,407,411	TRANS, P-CHAN, DMOSFET, VP055ON3 (TO-92)	TG-284
Q412	TRANS, PNP POWER, MJE350	TG-210
Q413	TRANS, NPN SILICON, MJE340	TG-209
Q414,420	TRANS, DUAL NPN IT121 (TO-52)	TG-91
R201-203,205,206,325-328,351,395,446,447,517,520,521,532	RES, 1K, 1%, 100MW, THICK FILM (0805)	R-418-1K
R204,511,512,514-516,518,519	RES, 274, 1%, 100MW, THICK FILM (0805)	R-418-274
R207,218,241,509	RES, 121K, 1%, 100MW, THICK FILM (0805)	R-418-121K
R208,209	RES, 140K, 1%, 100MW, THICK FILM (0805)	R-418-140K
R210,211,427	RES, 357K, 1%, 100MW, THICK FILM (0805)	R-418-357K
R212,213,311,401,420,421,491	RES, 49.9K, 1%, 100MW, THICK FILM (0805)	R-418-49.9K
R214,419,435	RES, 24.9K, 1%, 100MW, THICK FILM (0805)	R-418-24.9K
R215,228-231,340-345,402,405	RES, 4.99K, 1%, 100MW, THICK FILM (0805)	R-418-4.99K
R216	RES, 10K, 5%, 250MW, METAL FILM (1210)	R-376-10K
R219,221,223,437	RES, 1M, 0.1%, 1/4W, METAL FILM	R-374-1M
R220	RES, 5M, 5%, .25W, THICK FILM	R-432-5M
R222	RES, 50K, .1%, 1/10W, METAL FILM	R-263-50K
R224	RES, 500K, .1%, 1/10W, METAL FILM	R-263-500K
R266,225,227	RES, 1.5K, 1%, 100MW, THICK FILM (0805)	R-418-1.5K

**Table 7-3**  
*Model 6517A analog board, parts list (cont.)*

<b>Circuit designation</b>	<b>Description</b>	<b>Keithley part number</b>
R301,302,424,425,510,513	RES, 200K, 5%, 250MW, METAL FILM (1210)	R-376-200K
R303,306,310,321	RES, 2.21K, 1%, 100MW, THICK FILM (0805)	R-418-2.21K
R304,308,314,316,441,463	RES, 4.02K, 1%, 100MW, THICK FILM (0805)	R-418-4.02K
R305,307,312,318,494,495	RES, 100, 1%, 100MW, THICK FILM (0805)	R-418-100
R309,334,475-477	RES, 100K, 1%, 100MW, THICK FILM (0805)	R-418-100K
R313,335	RES, 75K, 1%, 100MW, THICK FILM (0805)	R-418-75K
R315,317,319,320,322,329,332	RES, 10M, 10%, 525MW, THICK FILM (1505)	R-430-10M
R323,415,508,492,493,433,458	RES, 499, 1%, 100MW, THICK FILM (0805)	R-418-499
R324	RES, 249, 1%, 100MW, THICK FILM (0805)	R-418-249
R336-339	RES, 2M, 1%, 100MW, THICK FILM (0805)	R-418-2M
R346	RES, 806, 1%, 100MW, THICK FILM (0805)	R-418-806
R347,459-462,502,240,217	RES, 1M, 1%, 100MW, THICK FILM (0805)	R-418-1M
R354	RES, 10M, 2%, 1W, 1500VDC, THICK FILM	R-417-10M
R358-360,397,398,414,448	RES, 10M, 10%, 525MW, THICK FILM (1505)	R-430-10M
R361	RES, 48.1K, .1%, 1/10W, METAL FILM	R-263-48.1K
R362	RES, 487K, .1%, 1/10W, METAL FILM	R-263-487K
R364,370,598	RES, 7.32, 1%, 100MW, THICK FILM (0805)	R-418-7.32
R367	RES, 59K, 1%, 100MW, THICK FILM (0805)	R-418-59K
R368	RES, 82.5, 1%, 100MW, THICK FILM (0805)	R-418-82.5
R369	RES, 66.5, 1%, 100MW, THICK FILM (0805)	R-418-66.5
R371	THICK FILM	TF-248
R373-389,449-453, 464-470, 527	RES, 470K, 5%, 250MW, METAL FILM (1210)	R-376-470K
R390-392,403,404,406,407,412	RES, 10K, 1%, 100MW, THICK FILM (0805)	R-418-10K
R396,523,504,416	RES, 2K, 1%, 100MW, THICK FILM (0805)	R-418-2K
R411	RES, 4T, 10%, 1W, 1500VDC, THICK FILM	R-429-4T
R413,525	RES, 249K, 1%, 100MW, THICK FILM (0805)	R-418-249K
R426,480,481	RES, 10, 10%, 100MW, THICK FILM (0805)	R-418-10
R428,429	RES, 24.3, 1%, 100MW, THICK FILM (0805)	R-418-24.3
R430,440	RES, 402K, 1%, 100MW, THICK FILM (0805)	R-418-402K
R431	RES, 1G, 10%, HIGH ALUMINA	R-435-1G
R432	RES, 1T, 10%, 1W, 1500VDC, THICK FILM	R-429-1T
R434,417	RES, 10K, 1%, 100MW, THICK FILM (0805)	R-418-10K
R436	RES, 255K, 1%, 100MW, THICK FILM (0805)	R-418-255K
R438,439,443	RES, 3K, 1%, 750MW, FILM	R-436-3K
R442	RES, 150K, 5%, 250MW, METAL FILM (1210)	R-376-150K
R490	RES, 30.1K, 1%, 100MW, THICK FILM (0805)	R-418-30.1K
R496,497	RES, 49.9, 1%, 100MW, THICK FILM (0805)	R-418-49.9
R501,506	RES, 392, 1%, 100MW, THICK FILM (0805)	R-418-392
R505	RES, 80.6K, 1%, 100MW, THIN FILM (0805)	R-438-80.6K
R507	RES, 24.9K, 1%, 100MW, THIN FILM (0805)	R-438-24.9K
R522	RES, 3.01K, 1%, 100MW, THICK FILM (0805)	R-418-3.01K
R524	RES, 80.6K, 1%, 100MW, THICK FILM (0805)	R-418-80.6K
R526	RES, 1K, 5%, 250MW, METAL FILM (1210)	R-376-1K
R530,531	RES, 1M, 5%, 250MW, METAL FILM (1210)	R-376-1M
R595	RES, 33.2, 1%, 100MW, THICK FILM (0805)	R-418-33.2

**Table 7-3**  
Model 6517A analog board, parts list (cont.)

Circuit designation	Description	Keithley part number
S101	SWITCH, PUSHBUTTON (6 POLE)	SW-466
S103	SWITCH, SLIDE (DPDT)	SW-476
U201,304,410	IC, 8-BIT SERIAL-IN LATCH DRIVER, 5841A	IC-536
U202,305,306,403,404	IC, 8 STAGE SHIFT/STORE REGISTER, 4094	IC-251
U204,311	IC, DUAL, VOLTAGE COMPARATOR, LM393	IC-343
U205	IC, NEG VOLTAGE REG -15V,500MA, 79M15	IC-195
U206	IC, POS VOLTAGE REG +15V,500MA, 7815	IC-194
U208	IC, 7V PRECISION REFERENCE, LT1021-7	IC-928
U209	IC, OP-AMP, LT1097	IC-803
U210,211	IC, CMOS, ANALOG SWITCH MAX326 16PIN DIP	IC-971
U212,312,409	IC, SPST CMOS ANALOG SWITCH, (DG411)	IC-667
U214	IC, 22V OP-AMP, LT1007ACN8	IC-422
U215	IC, 8-BIT CMOS MICROCTRL, P1C16C54-HS/P	IC-977
U220	IC, DUAL D-TYPE FLIP FLOP, 74HC74	IC-337
U301	IC, POS +12V VOLTAGE REG, 78L12	IC-522
U302	IC, NEG -12V VOLTAGE REG, LM79L12	IC-523
U303	PROGRAM	6517-801*
U307	IC, BIFET OP-AMP AD548KN	IC-970
U308	IC, 16 BIT VOLTAGE OUTPUT DAC, AD7846	IC-734
U309	IC, 5V REFERENCE, AD586L	IC-681
U310	IC, MOSFET DRIVER, TLP590A	IC-812
U313-318	IC, ADJ CURRENT SOURCE, LM234Z-6 (TO-92)	IC-961
U320	IC, UNDERVOLT SENSOR, MC34064	IC-716
U401,402,213,502	IC, DUAL JFET OP-AMP, LT1013	IC-423
U405	IC, 25FA, ELECTRO-AMP	IC-943
U406	IC, POWER VOLT REF, LT1004CZ 2.5 (TO-92)	IC-929
U407	IC, DUAL 12-BIT CMOS D/A CONV, DAC-8221	IC-927
U408,U207	IC, +5V VOLTAGE REGULATOR, LM2940CT	IC-576
U411-413	IC, LOW INPUT CURRENT OPTO, HCPL-2200	IC-411
U414	IC, CENTIGRADE TEMP SENSOR, LM35DZ(TO-92)	IC-933
U516	IC, OTC BFR/LINE DRIVER/REC, 74HCT244	IC-934
U501,503	IC, LINEAR OPTOCOUPLER, IL-300DEFG	IC-972
U504	IC, DUAL PICOAMP INPUT OP-AMP, AD706	IC-483
U505,506,508-513	IC, OPTOCOUPLER, TLP582	IC-689
VR301-304	DIODE, ZENER 24V, IN723 (D0-7)	DZ-17
VR306,307,309,310-312,401,402	DIODE, ZENER 9.1V, IN4739A (DO-35)	DZ-56
VR403,404	DIODE, ZENER 5.1V, IN751 (DO-7)	DZ-59
VR506,507,501,308,309	DIODE, ZENER 6.4V, IN4571 (D0-7)	DZ-60
Y301	CRYSTAL, 8.0000MHZ	CR-24-1

\*Order revision level.

**Table 7-4**  
 Model 6517A digital board, parts list

Circuit designation	Description	Keithley part number
	BATTERY HOLDER FOR BT1 DIGITAL ASSEMBLY SOCKET, 32 PIN FOR U637 AND U638	BH-34 6517-140 SO-103-32
CR603,605,607,609-618, 635-642 CR622 CR627,628	DIODE, SWITCHING, 250MA, BAV103 (SOD-80) DIODE, BRIDGE PE05 (CASE KBU) DIODE, ARRAY, MMAD1103 (SOIC)	RF-89 RF-48 RF-80
J1014	CONN, RT ANGLE, MALE, 9 PIN	CS-761-9
J1015,1016	CONN, CIRCULAR DIN	CS-762
J1018	CONN, RIGHT ANGLE, 24PIN	CS-507
J1029	CONN, HEADER STRAIGHT SOLDER PIN	CS-368-26
J1030	CONNECTOR, MALE, 4 PIN	CS-612-4
J1032	CONN, RT. ANGLE, MALE MOLEX .156	CS-715-4
J1033	CONN, HEADER STRAIGHT SOLDER PIN	CS-368-16
J1034	CONN, 48-PIN, 3-ROWS	CS-775-2
Q602-607	TRANS, N CHAN MOSPOW FET, 2N7000 (TO-92)	TG-195
R601,603-605,672	RES, 2K, 1%, 125mW, METAL FILM (1206)	R-391-2K
R616,621,625,629,631	RES, 10, 5%, 125MW, METAL FILM (1206)	R-375-10
R639	RES, 680K, 5%, 125mW, METAL FILM (1206)	R-375-680K
R644	RES NET, 4.7K, 2%, 1.875W (SOMIC)	TF-219-4.7K
R648-650,655-657	RES, 5.1K,5%, 125MW, METAL FILM (1206)	R-375-5.1K
R663,677,781-783	RES, 4.7K, 5%, 125MW, METAL FILM (1206)	R-375-4.7K
R665	RES, 470, 5%, 125MW, METAL FILM (1206)	R-375-470
R667,669	RES, 560, 5%, 250mW, METAL FILM (1210)	R-376-560
R668,717,720	RES, 10K, 5%, 250MW, METAL FILM (1210)	R-376-10K
R670,675	RES, 100, 5%, 250MW, METAL FILM (1210)	R-376-100
R714	RES, 4.7K, 5%, 250MW, METAL FILM (1210)	R-376-4.7K
R716	RES, 1M, 5%, 250MW, METAL FILM (1210)	R-376-1M
R718,719	RES, 1K, 5%, 250MW, METAL FILM (1210)	R-376-1K
R732,749,771	RES, 10K, 5%, 125MW, METAL FILM (1206)	R-375-10K
R743-748,752-755,757, 769,774,	RES, 100, 5%, 125MW, METAL FILM (1206)	R-375-100
R758-763	RES, 39, 5%, 125MW, METAL FILM (1206)	R-375-39
R772	RES, 47K, 5%, 125MW, METAL FILM (1206)	R-375-47K
R787	RES, 510, 5%, 125MW, METAL FILM (1206)	R-375-510
R788	RES, 33.2, 1%, 100MW, THICK FILM (0805)	R-418-33.2
R789,791	RES, 110K, 1%, 100MW, THICK FILM (0805)	R-418-110K
R792,790	RES, 576K, 1%, 100MW, THICK FILM (0805)	R-418-576K
R793	RES, 20, 1%, 100MW, THICK FILM (0805)	R-418-20
TP602-603	CONN, TEST POINT	CS-553

**Table 7-4**  
 Model 6517A digital board, parts list (cont.)

Circuit designation	Description	Keithley part number
U612	IC, 350MA SATURATED SINK DRIVER UDN-2596A	IC-578
U614	IC, OCT BFR/LINE DRIVE, 74HCT244 (SOLIC)	IC-651
U615,630	IC, QUAD 2 IN NOR, 74HCT02 (SOIC)	IC-809
U616	IC, QUAD 2 INPUT OR, 74HCT32 (SOIC)	IC-808
U621	IC, OCTAL INTERFACE BUS, 75160 (SOLIC)	IC-646
U622	IC, GPIB ADAPTER, 9914A (PLCC)	LSI-123
U623	IC, OCTAL INTER BUS TRANS, 75161 (SOLIC)	IC-647
U628	IC, VOLT COMPARATOR, LM393D (SOIC)	IC-775
U629,642	IC, +5V VOLTAGE REGULATOR, LM2940CT	IC-576
U631	IC, 16-BIT MICRO, MC68302FC	LSI-144
U634	IC, SERIAL E EPROM, X24164 (8-PIN DIP)	IC-885
U635,636	IC, 125KX8 STAT CMOS RAM, HM628128LFP-10	LSI-133-100
U639	IC, MICROMANAGER, DS12365-10 (SOLIC)	IC-884
U640	IC, 64X8 CMOS SRAM MK41756N00	IC-946
U641	IC, +5V RS-232 TRANSCEIVER, MAX202 (SOIC)	IC-952
U643	IC, VOLT CONVERT, LT 1026	IC-959
U652	IC, PROG, VOLT, REG, ICL7664	IC-883
U653	IC, PROG, VOLT, REG, ICL7663	IC-882
VR602	DIODE, ZENER 4.7V, IN4732A (DO-41)	DZ-67
W607-610	CONN, 3 PIN	CS-339-3
W607-610	CONNECTOR, JUMPER	CS-476

**Table 7-5**  
*Model 6517A mechanical board, parts list*

Circuit designation	Description	Keithley part number
	.020 VINYL STOCK	D-1
	BEZEL, REAR	428-303D
	CARD GUIDE, LONG	2001-315A
	CARD GUIDE, SHORT	2001-316A
	CHASSIS ASSEMBLY	6517-305B
	CLIP, REGULATOR	6517-324A
	COLLAR	6517-323A
	CONDUCTIVE RUBBER SWITCH	6517-310A
	CONNECTOR FOR SC-146, SC-147	CS-236
	CONNECTOR FOR SC-68-0,-2,SC-144-2,-3,-4,	CS-236
	CONNECTOR FOR SC-71-1, SC-71-6	CS-276
	CONNECTOR, HARDWARE KIT IEEE CS TO R. PANEL	CS-713
	COVER	6517-319B
	COVER PANEL, SCANNER	2001-372A
	CRIMP CONTACT ROUND FOR SC-147	CS-760
	DISPLAY LENS	6517-307B
	FOOT	428-319A
	FOOT, EXTRUDED	FE-22A
	FOOT, RUBBER	FE-6
	GASKET	GA-30A
	HANDLE	428-329F
	INSULATOR	27493-46V
	INSULATOR	27493-47V
	INSULATOR	27493-48V
	LENS, LED	6517-309A
	LUG FOR SC-73-5	LU-88
	MOUNTING EAR, LEFT	428-338B
	MOUNTING EAR, RIGHT	428-328E
	OVERLAY, FRONT PANEL	6517-312A
	PAD, THERMAL	HS-47A
	PC BOARD STOP	2001-371A
	PLASTIC PLUG COVER PLATE TO R. PANEL	FA-240
	POWER ROD	2001-320A
	PRINTED FRONT PANEL	6517-302B
	RFI CLIP, CHASSIS	2001-366-14A
	RFI CLIP, CHASSIS	2001-366-5A
	SCREWLOCK, FEMALE RT ANGLE CS TO R. PANEL	CS-725
	SHIELD, A/D BOTTOM	6517-316A
	SHIELD, A/D TOP	6517-317A
	SHIELD, ELECTROMETER BOTTOM	6517-315A
	SHIELD, ELECTROMETER TOP	6517-314A
	SHIELD, INPUT WIRE FOR CS-630	6517-320A
	SHORTING LINK	BP-6
	SPACER	6517-322A
	TRANSFORMER	TR-297A



**Table 7-5**  
 Model 6517A mechanical board, parts list (cont.)

<b>Circuit designation</b>	<b>Description</b>	<b>Keithley part number</b>
DS301	LED, HIGH POWER	PL-94
J1001	CONN, AC RECEPTACLE (LINE FILTER)	LF-6-1
J1003	CONNECTOR TRIAX	CS-630
J1004	BINDING POST, YELLOW	BP-11-7
J1005	BINDING POST, BLACK	BP-11-0
J1006	BINDING POST, BLUE	BP-11-6
J1007	BINDING POST, GREEN	BP-11-5
J1008	BANANA JACK, PUSH-IN, RED	BJ-13-2
J1009	BANANA JACK, PUSH-IN, BLACK	BJ-13-0
J1017	CONNECTOR, 4-PIN MALE	CS-458
P1002	CONN, MOLEX HEADER	CS-716-3
P1019,P1020	CONNECTOR	CS-627
P1021-1023	CONNECTOR, HOUSING	CS-638-3
P1030	CONN, BERG HOUSING	CS-638-4

**Table 7-6**  
 Model 6517A miscellaneous parts list

<b>Description</b>	<b>Keithley part number</b>
LINE CORD	CO-7
CAP, PROTECTIVE	CAP-31
SOFTWARE DISK	6517-DSK-81

# B

## Calibration Messages

---

### B.1 Introduction

This appendix lists error query commands, errors that may occur during calibration, and summarizes the :CAL:PROT:DATA? query response messages.

### B.2 Error summary

Table B-1 lists Model 6517A calibration error queries, and Table B-2 summarizes Model 6517A calibration errors. The errors listed in Table B-1 may be requested with the :SYSTem:ERRor? query, while responses to error queries listed in Table B-2 are shown in Figure B-1 through Figure B-8.

**Table B-1**  
Calibration error responses

Error number	Message	Description
Volts Function Errors		
+350	“2V offset out of spec”	2V range offset error
+351	“2V pgain out of spec”	2V range positive slope error
+352	“2V ngain out of spec”	2V range negative slope error
+353	“20V offset out of spec”	20V range offset error
+354	“20V pgain out of spec”	20V range positive slope error
+355	“20V ngain out of spec”	20V range negative slope error
+356	“200V offset out of spec”	200V range offset error
+357	“200V pgain out of spec”	200V range positive slope error
+358	“200V ngain out of spec”	200V range negative slope error
Current Function Errors		
+359	“20pA offset out of spec”	20pA range offset error
+360	“20pA pgain out of spec”	20pA range positive slope error
+361	“20pA ngain out of spec”	20pA range negative slope error
+362	“200pA offset out of spec”	200pA range offset error
+363	“200pA pgain out of spec”	200pA range positive slope error
+364	“200pA ngain out of spec”	200pA range negative slope error
+365	“2nA offset out of spec”	2nA range offset error
+366	“2nA pgain out of spec”	2nA range positive slope error
+367	“2nA ngain out of spec”	2nA range negative slope error
+368	“20nA offset out of spec”	20nA range offset error
+369	“20nA pgain out of spec”	20nA positive slope error
+370	“20nA ngain out of spec”	20nA negative slope error
+371	“200nA offset out of spec”	200nA range offset error
+372	“200nA pgain out of spec”	200nA range positive slope error
+373	“200nA ngain out of spec”	200nA range negative slope error
+374	“2uA offset out of spec”	2uA range offset error
+375	“2uA pgain out of spec”	2uA range positive slope error
+376	“2uA ngain out of spec”	2uA range negative slope error
+377	“20uA offset out of spec”	20uA range offset error
+378	“20uA pgain out of spec”	20uA range positive slope error
+379	“20uA ngain out of spec”	20uA range negative slope error
+380	“200uA offset out of spec”	200uA range offset error
+381	“200uA pgain out of spec”	200uA range positive slope error
+382	“200uA ngain out of spec”	200uA range negative slope error
+383	“2mA offset out of spec”	2mA range offset error
+384	“2mA pgain out of spec”	2mA range positive slope error
+385	“2mA ngain out of spec”	2mA range negative slope error
+386	“20mA offset out of spec”	20mA range offset error
+387	“20mA pgain out of spec”	20mA range positive slope error
+388	“20mA ngain out of spec”	20mA range negative slope error
Charge Function Errors		
+389	“2nC pgain out of spec”	2nC range positive slope error
+390	“2nC ngain out of spec”	2nC range negative slope error
+391	“20nC pgain out of spec”	20nC range positive slope error
+392	“20nC ngain out of spec”	20nC range negative slope error
+393	“200nC pgain out of spec”	200nC range positive slope error

**Table B-1**  
Calibration error responses (cont.)

Error number	Message	Description
Charge Function Errors (cont.)		
+394	“200nC ngain out of spec”	200nC range negative slope error
+395	“2uC pgain out of spec”	2uC range positive slope error
+396	“2uC ngain out of spec”	2uC range negative slope error
Temperature Function Errors		
+399	“Temperature offset out of spec”	Temperature function offset error
+400	“Temperature gain out of spec”	Temperature function gain error
Humidity Function Errors		
+409	“Hum. 50% offset out of spec”	50% humidity offset error
+410	“Hum. 100% offset out of spec”	100% humidity offset error
+411	“Hum. 50% gain out of spec”	50% humidity gain error
+412	“Hum. 100% gain out of spec”	100% humidity gain error
Offset Calibration Errors		
+413	“Voltage Offset not converging”	Voltage offset calibration error
+414	“Current Offset not converging”	Current offset calibration error
Voltage Source Errors		
+415	“VSRC 100V offset out of spec”	100V range offset error
+416	“VSRC 100V pgain out of spec”	100V range positive slope error
+417	“VSRC 100V ngain out of spec”	100V range negative slope error
+418	“VSRC 1kV offset out of spec”	1000V range offset error
+419	“VSRC 1kV pgain out of spec”	1000V range positive slope error
+420	“VSRC 1kV ngain out of spec”	1000V range negative slope error
Factory Calibration Errors		
+421	“Voltage Offset out of spec”	
+422	“Current Offset out of spec”	
+423	“Zero Check CAL Error”	
Calibration Execution Errors		
+424	“Date of calibration not set”	Calibration date not set error
+425	“Next date of calibration not set”	Calibration due date not set error
+426	“Calibration not initialized”	Calibration not initialized error
+427	“Illegal Calibration Command”	Illegal calibration command error
Power-on Errors		
+513	“Calibration data lost”	Calibration data lost error
+514	“Calibration dates lost”	Calibration dates lost error
+515	“Calibration tolerances lost”	Calibration tolerances lost error
+516	“Calibration tables lost”	Calibration tables lost error
+517	“Voltage Offset lost”	Voltage offset value lost error
+518	“Current Offset lost”	Current offset value lost error
+519	“Installed option id lost”	Option ID lost error
+520	“Option card not supported”	Option card not supported error
+521	“Cal Card Data Error”	Calibration unit data error

Note: Bus response to query includes error number, comma, and error message surrounded by double quotes.

**Table B-2**  
*Calibration error query commands*

<b>Error number</b>	<b>Message</b>	<b>Figure</b>
:CALibration: UNPRotected:		
EERR?	Request cal execution error status	B-1
VERR?	Request voltage function cal errors	B-2
AERR?	Request current function cal errors	B-3
CERR?	Request charge function cal errors	B-4
TERR?	Request temperature function cal errors	B-5
HERR?	Request humidity function cal errors	B-6
SERR?	Request voltage source cal errors	B-7
FERR?	Request factory cal errors	B-8

**Table B-3**

Calibration constants returned by :CAL:PROT:DATA?  
query

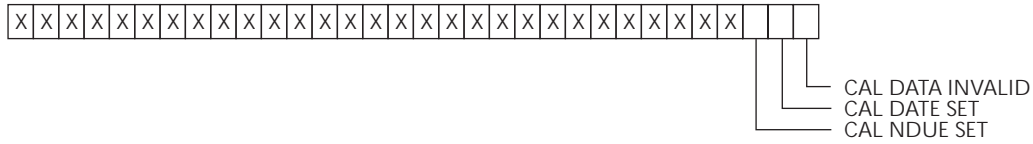
Order	Calibration constant description
1	Volts function 2V range zero offset
2	Volts function 2V range positive slope
3	Volts function 2V range negative slope
4	Volts function 20V range zero offset
5	Volts function 20V range positive slope
6	Volts function 20V range negative slope
7	Volts function 200V range zero offset
8	Volts function 200V range positive slope
9	Volts function 200V range negative slope
10	Amps function 20pA range zero offset
11	Amps function 20pA range positive slope
12	Amps function 20pA range negative slope
13	Amps function 200pA range zero offset
14	Amps function 200pA range positive slope
15	Amps function 200pA range negative slope
16	Amps function 2nA range zero offset
17	Amps function 2nA range positive slope
18	Amps function 2nA range negative slope
19	Amps function 20nA range zero offset
20	Amps function 20nA range positive slope
21	Amps function 20nA range negative slope
22	Amps function 200nA range zero offset
23	Amps function 200nA range positive slope
24	Amps function 200nA range negative slope
25	Amps function 2μA range zero offset
26	Amps function 2μA range positive slope
27	Amps function 2μA range negative slope
28	Amps function 20μA range zero offset
29	Amps function 20μA range positive slope
30	Amps function 20μA range negative slope
31	Amps function 200μA range zero offset
32	Amps function 200μA range positive slope
33	Amps function 200μA range negative slope
34	Amps function 2mA range zero offset
35	Amps function 2mA range positive slope
36	Amps function 2mA range negative slope
37	Amps function 20mA range zero offset
38	Amps function 20mA range positive slope
39	Amps function 20mA range negative slope
40	Coulombs function 2nC range zero check A
41	Coulombs function 2nC range zero check B
42	Coulombs function 2nC range positive slope
43	Coulombs function 2nC range negative slope
44	Coulombs function 20nC range zero check A
45	Coulombs function 20nC range zero check B

**Table B-3**

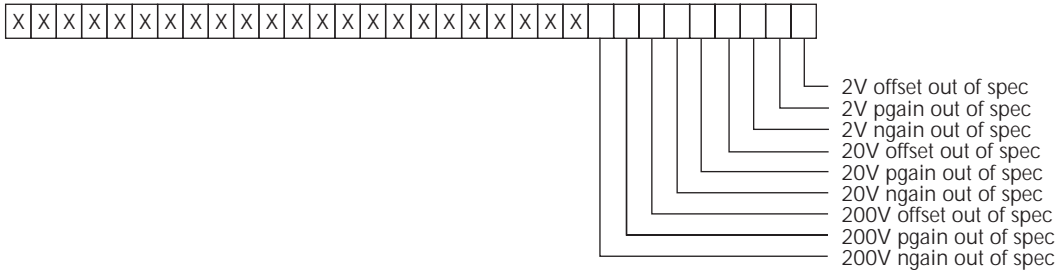
Calibration constants returned by :CAL:PROT:DATA?  
query (cont.)

Order	Calibration constant description
46	Coulombs function 20nC range positive slope
47	Coulombs function 20nC range negative slope
48	Coulombs function 200nC range zero check A
49	Coulombs function 200nC range zero check B
50	Coulombs function 200nC range positive slope
51	Coulombs function 200nC range negative slope
52	Coulombs function 2nC range zero check A
53	Coulombs function 2nC range zero check B
54	Coulombs function 2nC range positive slope
55	Coulombs function 2nC range negative slope
56	Temperature function offset
57	Temperature function slope
58	Internal temperature
59	Humidity function 0V offset
60	Humidity function 0V slope
61	Humidity function 1V offset
62	Humidity function 1V slope
63	Volts function 2V range zero check offset
64	Volts function 20V range zero check offset
65	Volts function 200V range zero check offset
66	Amps function 20pA range zero check offset
67	Amps function 200pA range zero check offset
68	Amps function 2nA range zero check offset
69	Amps function 20nA range zero check offset
70	Amps function 200nA range zero check offset
71	Amps function 2μA range zero check offset
72	Amps function 20μA range zero check offset
73	Amps function 200μA range zero check offset
74	Amps function 2mA range zero check offset
75	Amps function 20mA range zero check offset
76	Coulombs function 2nC range zero check offset
77	Coulombs function 20nC range zero check offset
78	Coulombs function 200nC range zero check offset
79	Coulombs function 2μC range zero check offset
80	Voltage source 100V range zero offset
81	Voltage source 100V range positive slope
82	Voltage source 100V range negative slope
83	Voltage source 1000V range zero offset
84	Voltage source 1000V range positive slope
85	Voltage source 1000V range negative slope

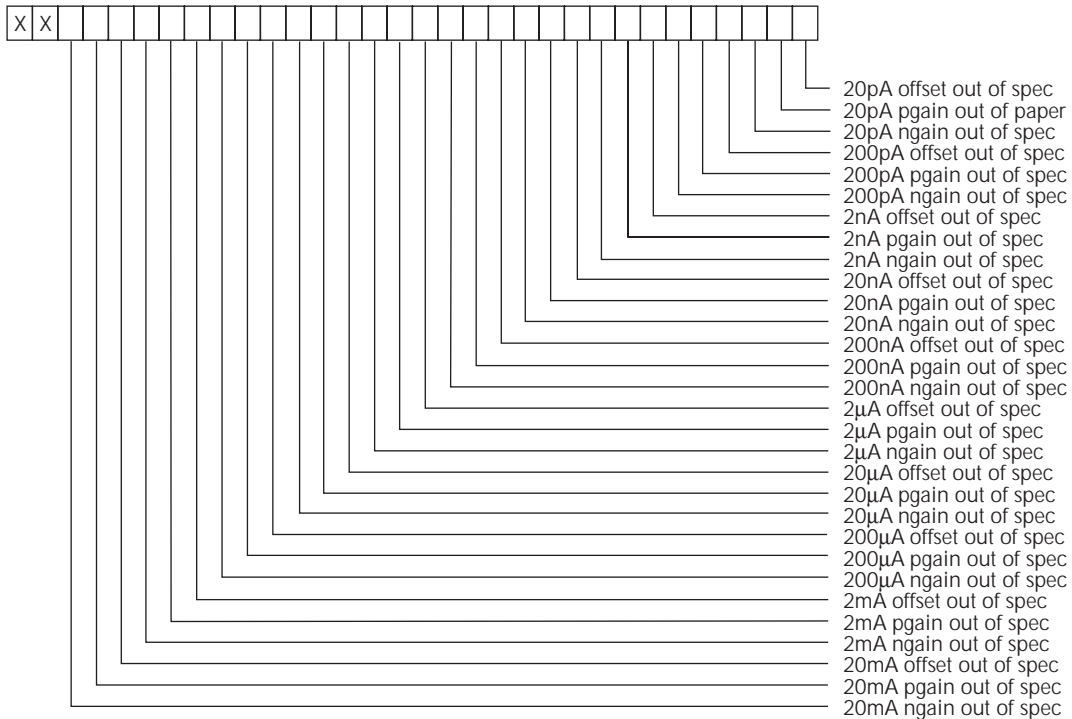
NOTE: Constants are returned as an ASCII string of floating-point numbers separated by commas. Constants are sent in the order shown, and entire string is terminated by a newline (<LF> + EOI).



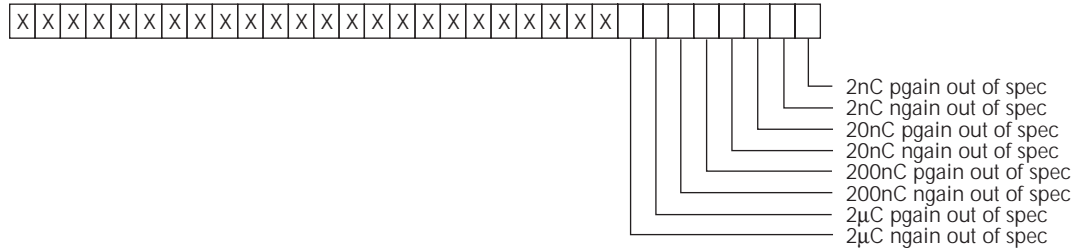
**Figure B-1**  
*EERR? query response (calibration execution errors)*



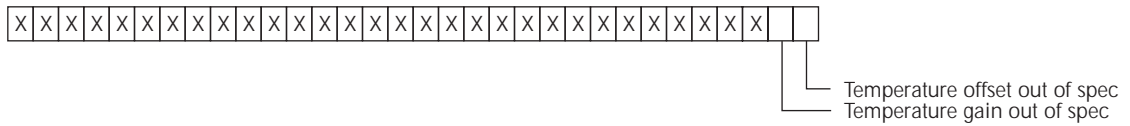
**Figure B-2**  
*VERR? query response (voltage function cal errors)*



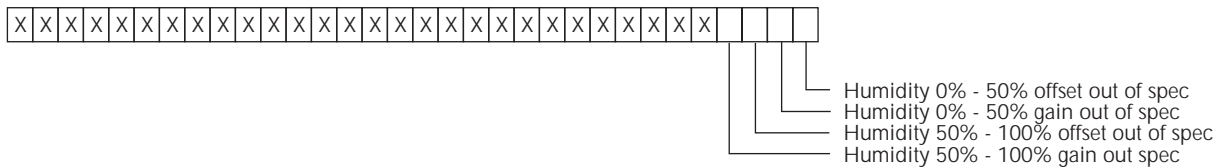
**Figure B-3**  
*IERR? query response (current function cal errors)*



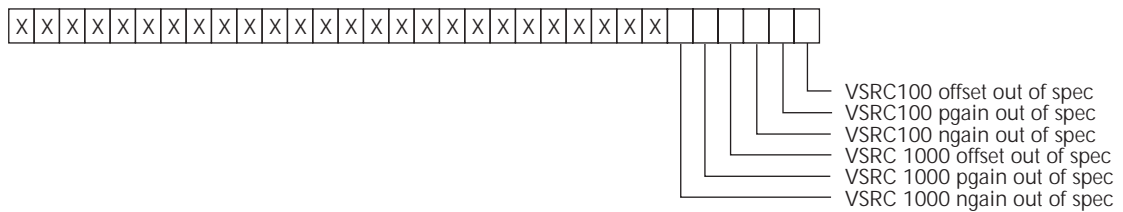
**Figure B-4**  
*CERR? query response (coulombs function cal errors)*



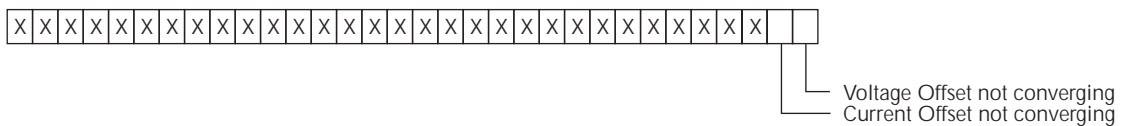
**Figure B-5**  
*TERR? query response (temperature function cal errors)*



**Figure B-6**  
*HERR? query response (humidity function cal errors)*



**Figure B-7**  
*VSRR? query response (voltage source cal errors)*



**Figure B-8**  
*FERR? query response (factor cal errors)*



# C

## Calibration Command Summary

**Table C-1**  
Calibration commands

Command	Description
CALibration:	Calibration subsystem
PROTected:	Commands protected by CAL switch
INITiate	Required before performing ANY cal steps
VZERO2	2V range zero step
V2 <Nrf>	+2V step
VN2 <Nrf>	-2V step
VZERO20	20V range zero step
V20 <Nrf>	+20V step
VN20 <Nrf>	-20V step
VZERO200	200V range zero step
V200 <Nrf>	+200V step
VN200 <Nrf>	-200V step
AZERO20P	20pA range zero step
A20P <Nrf>	+20pA step
A20PCARD <Nrf>	+20pA step (using cal standard)
AN20P <Nrf>	-20pA step
AN20PCARD <Nrf>	-20pA step (using cal standard)
AZERO200P	200pA range zero step
A200P <Nrf>	+200pA step
A200PCARD <Nrf>	+200pA step (using cal standard)
AN200P <Nrf>	-200pA step
AN200PCARD <Nrf>	-200pA step (using cal standard)
AZERO2N	2nA range zero step
A2N <Nrf>	+2nA step
A2NCARD <Nrf>	+2nA step (using cal standard)
AN2N <Nrf>	-2nA step
AN2NCARD <Nrf>	-2nA step (using cal standard)
AZERO20N	20nA range zero step
A20N <Nrf>	+20nA step
A20NCARD <Nrf>	+20nA step (using cal standard)

**Table C-1**  
Calibration commands (cont.)

Command	Description
CALibration:	
PROTected:	
AN20N <Nrf>	-20nA step
AN20NCARD <Nrf>	-20nA step (using cal standard)
AZERO200N	200nA range zero step
A200N <Nrf>	+200nA step
A200NCARD <Nrf>	+200nA step (using cal standard)
AN200N <Nrf>	-200nA step
AN200NCARD <Nrf>	-200nA step (using cal standard)
AZERO2U	2μA range zero step
A2U <Nrf>	+2μA step
A2UCARD <Nrf>	+2μA step (using cal standard)
AN2U <Nrf>	-2μA step
AN2UCARD <Nrf>	-2μA step (using cal standard)
AZERO20U	20μA range zero step
A20U <Nrf>	+20μA step
AN20U <Nrf>	-20μA step
AZERO200U	200μA range zero step
A200U <Nrf>	+200μA step
AN200U <Nrf>	-200μA step
AZERO2M	2mA range zero step
A2M <Nrf>	+2mA step
AN2M <Nrf>	-2mA step
AZERO20M	2mA range zero step
A20M <Nrf>	+20mA step
AN20M <Nrf>	-20mA step
CZEROA2N	2nC range zero check part A
C2N <Nrf>	+2nC step
C2NCARD <Nrf>	+2nC step (using cal standard)
CZEROB2N	2nC range zero check part B
CN2N <Nrf>	-2nC step
CN2NCARD <Nrf>	-2nC step (using cal standard)
CZEROA20N	20nC range zero check part A
C20N <Nrf>	+20nC step
C20NCARD <Nrf>	+20nC step (using cal standard)
CZEROB20N	20nC range zero check part B
CN20N <Nrf>	-20nC step
CN20NCARD <Nrf>	-20nC step (using cal standard)
CZEROA200N	200nC range zero check part A
C200N <Nrf>	+200nC step
C200NCARD <Nrf>	+200nC step (using cal standard)
CZEROB200N	200nC range zero check part B
CN200N <Nrf>	-200nC step
CN200NCARD <Nrf>	-200nC step (using cal standard)
CZEROA2U	2μC range zero check part A
C2U <Nrf>	+2μC step
C2UCARD <Nrf>	+2μC step (using cal standard)
CZEROB2U	2μC range zero check part B
CN2U <Nrf>	-2μC step
CN2UCARD <Nrf>	-2μC step (using cal standard)

**Table C-1**  
Calibration commands (cont.)

Command	Description
CALibration:	
PROTected:	
TZERO	0mV (0°C) temperature step
T100	+4.095mV (100°C) temperature step
VSETZ100	Set voltage source to 0V for next command
VSR CZ100 <Nrf>	Voltage source 100V range 0V cal
VSETZ1000	Set voltage source to 0V for next command
VSR CZ1000 <Nrf>	Voltage source 1000V range 0V cal
VSET40	Set voltage source to +40V
VSR C40 <Nrf>	Voltage source +40 V cal
VSET100	Set voltage source to +100V
VSR C100 <Nrf>	Voltage source +100V cal
VSETN100	Set voltage source to -100V
VSR CN100 <Nrf>	Voltage source -100V cal
VSET400	Set voltage source to +400V
VSR C400 <Nrf>	Voltage source +400V cal
VSET1000	Set voltage source to +1000V
VSR C1000 <Nrf>	Voltage source +1000 V cal
VSETN1000	Set voltage source to -1000 V
VSR CN1000 <Nrf>	Voltage source -1000 V cal
HUMZERO	Humidity input 0 V step
HUM05	Humidity input 0.5 V step
HUM1	Humidity input 1.0 V step
LOCK	Re-locks the calibration paths. (A new CAL switch press and CAL:PROT:INIT command are required before any cal commands can be performed again.)
SAVE	Saves the cal constants in NVRAM
DATE <yyyy, mm, dd>	Calibration date yyyy = year (1994-2093), mm = month (1-12), dd =date (1-31)
DATE?	Request calibration date
NDUE <yyyy, mm, dd>	Calibration due date
NDUE?	Request calibration due date
SWITCh?	Request CAL switch state (0 = unlocked, 1 = locked)
CALTEMP	Acquire the calibration temperature.
UNPRotected:	These commands not protected by CAL switch
VOFFset	Perform offset voltage calibration
IOFFset	Perform bias current calibration
EERR?	Request cal execution error status
VERR?	Request voltage function cal errors
AERR?	Request amps function cal errors
CERR?	Request coulombs function cal errors
TERR?	Request temperature function cal errors
FERR?	Request factory calibration errors
OPTion?	Request cal option presence status

NOTE: Upper-case letters indicate short form of each command. For example, instead of sending “:CALibration:PROTected:INITiate”, you can send “:CAL:PROT:INIT”.

## Numerics

2G $\Omega$ -200G $\Omega$  range verification 1-13  
2M $\Omega$ -200M $\Omega$  range verification 1-11  
2T $\Omega$ -200T $\Omega$  range verification 1-13  
2V analog output 5-9  
20 $\mu$ A-20mA range verification 1-8  
20pA-2 $\mu$ A range verification 1-6

## Symbols

:CALTEMP 3-8  
:DATA? 3-8  
:DATE 3-7  
:INIT 3-5  
:IOFF 3-9  
:LOCK 3-5  
:NDUE 3-7  
:OPT? 3-8  
:SAVE 3-6  
:SWITCh? 3-6

## A

A/D converter board removal 6-3  
A/D converter interface 5-6  
A/D input buffer 5-9  
Amps calibration commands 3-11  
Analog board 5-7  
Analog board checks 5-13  
Analog board removal 6-3  
Assembly drawings 6-5

## C

Calculating ohms reading limits 1-11  
Calibration 2-1  
Calibration command reference 3-1  
Calibration command summary C-1  
Calibration commands 2-15  
Calibration errors 2-4, 3-17  
Calibration lock 2-4  
Calibration messages B-1  
Case cover removal 6-2

Character set test 5-2  
Circuit board checks 5-10  
Command summary 3-1  
Component layouts 7-1  
Coulombs calibration commands 3-13  
Coulombs verification 1-9

## D

DC amps verification 1-6  
DC circuits 5-6  
DC volts verification 1-6  
Detecting calibration errors 3-18  
Detecting calibration step completion 3-18  
Digital board 5-6  
Digital board checks 5-12  
Digital board removal 6-3  
Disassembly 6-1  
Display board 5-4  
Display board checks 5-10  
Display microcontroller 5-4  
DISPLAY PATTERNS Test 5-2

## E

Environmental conditions 1-1, 2-2  
Error query commands 3-17  
Error queue 3-18  
Error summary B-1

## F

Factory service 7-1  
Firmware updates 4-2  
Front panel calibration 2-4  
Front panel calibration procedure 2-6  
Front panel calibration summary 2-4  
Front panel disassembly 6-4  
Front panel error reporting 2-4  
Front panel offset calibration 1-5  
Front panel single-point calibration 2-21  
Front panel tests 5-2

## G

Generating an SRQ on calibration complete 3-18  
Generating an SRQ on error 3-18

## H

Handling and cleaning precautions 6-1  
Humidity calibration commands 3-16  
Humidity verification 1-16  
Humidity verification equipment 1-4

## I

IEEE-488 bus calibration 2-15  
IEEE-488 bus calibration lock status 2-4  
IEEE-488 bus comprehensive calibration procedure 2-15  
IEEE-488 bus error reporting 2-4  
IEEE-488 bus offset calibration 1-5  
IEEE-488 bus single-point calibration 2-22  
IEEE-488 interface 5-6  
INPUT connector cleaning 4-2  
Input preamplifier 5-7  
Instrument re-assembly 6-5  
Instrument setup 1-11  
Introduction 1-1, 2-1, 3-1, 4-1, 5-1, 6-1, B-1

## K

Key matrix 5-4  
KEYS test 5-2

## L

Line fuse replacement 4-1  
Line power 1-2, 2-2  
Line power circuits 5-6  
Line voltage selection 4-1

## **M**

Main CPU firmware replacement 6-4  
Memory circuits 5-6  
Meter commands 3-9  
Meter performance verification equipment  
1-2  
Meter verification procedures 1-5  
Microprocessor 5-6  
Miscellaneous commands 3-5  
Multiplexer 5-9

## **O**

Offset commands 3-9  
Offset compensation 5-9  
Offset voltage and bias current calibration  
1-5  
Ohms verification 1-11  
Ordering information 7-1

## **P**

Parts list 7-1  
PC board handling 6-1  
PC board removal 6-2  
Performance verification 1-1  
Power supply 5-4  
Power supply checks 5-11

Power supply circuits 5-7  
Power-on test 5-2  
Prescaler 5-9  
Principles of operation 5-2  
Programming calibration dates 2-23

## **R**

Reading limit calculation example 1-4  
Recommended calibration equipment 2-2  
Recommended test equipment 1-2  
Repair considerations 5-1  
Replaceable parts 7-1  
Required standard resistors 1-11  
Restoring default conditions 1-4  
Routine maintenance 4-1  
RS-232 interface 5-6

## **S**

Selecting auto voltage source mode 1-11  
Selecting internal voltage source connections 1-11  
Single-point calibration 2-21  
Solder repairs 6-2  
Special handling of static-sensitive devices  
6-2  
Specifications A-1  
Status byte EAV (Error Available) bit 3-18

## **T**

Temperature and humidity circuits 5-9  
Temperature calibration commands 3-16  
Temperature verification 1-15  
Temperature verification equipment 1-3  
Trigger and digital I/O circuits 5-6  
Troubleshooting 5-1

## **U**

Unlocking calibration 2-4  
Using the \*OPC command 3-18  
Using the \*OPC? query 3-18

## **V**

Vacuum fluorescent display 5-4  
Verification limits 1-4  
Voltage source 5-10  
Voltage source calibration  
commands 3-15  
Voltage source verification 1-14  
Voltage source verification equipment 1-3  
Volts function calibration commands 3-10

## **W**

Warm-up period 1-2, 2-2



# Service Form

Model No. \_\_\_\_\_ Serial No. \_\_\_\_\_ Date \_\_\_\_\_

Name and Telephone No. \_\_\_\_\_

Company \_\_\_\_\_

List all control settings, describe problem and check boxes that apply to problem. \_\_\_\_\_

- |  |  |  |
|--|--|--|
| <input type="checkbox"/> Intermittent            | <input type="checkbox"/> Analog output follows display   | <input type="checkbox"/> Particular range or function bad; specify _____ |
| <input type="checkbox"/> IEEE failure            | <input type="checkbox"/> Obvious problem on power-up     | <input type="checkbox"/> Batteries and fuses are OK                      |
| <input type="checkbox"/> Front panel operational | <input type="checkbox"/> All ranges or functions are bad | <input type="checkbox"/> Checked all cables                              |

Display or output (check one)

- |                                   |  |
|-----------------------------------|--|
| <input type="checkbox"/> Drifts   | <input type="checkbox"/> Unable to zero              |
| <input type="checkbox"/> Unstable | <input type="checkbox"/> Will not read applied input |
| <input type="checkbox"/> Overload |  |

- |   |  |
|---|--|
| <input type="checkbox"/> Calibration only | <input type="checkbox"/> Certificate of calibration required |
| <input type="checkbox"/> Data required    |  |

(attach any additional sheets as necessary)

Show a block diagram of your measurement system including all instruments connected (whether power is turned on or not). Also, describe signal source.

Where is the measurement being performed? (factory, controlled laboratory, out-of-doors, etc.)

What power line voltage is used? \_\_\_\_\_ Ambient temperature? \_\_\_\_\_ °F

Relative humidity? \_\_\_\_\_ Other? \_\_\_\_\_

Any additional information. (If special modifications have been made by the user, please describe.)

Be sure to include your name and phone number on this service form.

**KEITHLEY**

**Keithley Instruments, Inc.**

28775 Aurora Road  
Cleveland, Ohio 44139

Printed in the U.S.A.